

# DA-820 Series Embedded Computer User's Manual

---

First Edition, October 2014

[www.moxa.com/product](http://www.moxa.com/product)

**MOXA**<sup>®</sup>

© 2014 Moxa Inc. All rights reserved.

# DA-820 Series Embedded Computer User's Manual

The software described in this manual is furnished under a license agreement and may be used only in accordance with the terms of that agreement.

## Copyright Notice

© 2014 Moxa Inc. All rights reserved.

## Trademarks

The MOXA logo is a registered trademark of Moxa Inc.  
All other trademarks or registered marks in this manual belong to their respective manufacturers.

## Disclaimer

Information in this document is subject to change without notice and does not represent a commitment on the part of Moxa.

Moxa provides this document as is, without warranty of any kind, either expressed or implied, including, but not limited to, its particular purpose. Moxa reserves the right to make improvements and/or changes to this manual, or to the products and/or the programs described in this manual, at any time.

Information provided in this manual is intended to be accurate and reliable. However, Moxa assumes no responsibility for its use, or for any infringements on the rights of third parties that may result from its use.

This product might include unintentional technical or typographical errors. Changes are periodically made to the information herein to correct such errors, and these changes are incorporated into new editions of the publication.

## Technical Support Contact Information

[www.moxa.com/support](http://www.moxa.com/support)

### **Moxa Americas**

Toll-free: 1-888-669-2872  
Tel: +1-714-528-6777  
Fax: +1-714-528-6778

### **Moxa Europe**

Tel: +49-89-3 70 03 99-0  
Fax: +49-89-3 70 03 99-99

### **Moxa India**

Tel: +91-80-4172-9088  
Fax: +91-80-4132-1045

### **Moxa China (Shanghai office)**

Toll-free: 800-820-5036  
Tel: +86-21-5258-9955  
Fax: +86-21-5258-5505

### **Moxa Asia-Pacific**

Tel: +886-2-8919-1230  
Fax: +886-2-8919-1231

# Table of Contents

<b>1. Introduction</b>	<b>1-1</b>
Overview	1-2
Model Descriptions and Package Checklist	1-2
Appearance	1-3
Dimensions	1-4
Features	1-4
Hardware Block Diagram	1-5
DA-820 Basic System	1-5
Hardware Specifications	1-5
<b>2. Hardware Installation</b>	<b>2-1</b>
Wiring Requirements	2-2
Connecting the Power	2-2
Wiring the Power Inputs	2-3
HIPOT (Dielectric Strength) Testing	2-8
Reset Button	2-9
LED	2-9
Connecting to a Display	2-10
Connecting USB Devices	2-10
Gigabit LAN Ports	2-11
Upgrading the Memory Module	2-12
Installing a CFast Card	2-13
Installing SATA Hard Disks	2-14
<b>3. BIOS Setup</b>	<b>3-1</b>
Entering the BIOS Setup	3-2
Main Information	3-3
Advanced Settings	3-3
Boot Configuration	3-4
HDC Configuration	3-4
Video Configuration	3-7
PCI Express Graphics	3-9
Chipset Configuration	3-10
Active Management Technology Support	3-11
PCI Express Configuration	3-12
Hardware Monitor	3-13
SMART RECOVERY Info	3-14
Security Settings	3-15
TPM Status	3-15
TPM Operation	3-15
TPM Force Clear	3-16
Set Supervisor Password	3-16
Power Settings	3-17
Turbo Mode	3-17
TXT	3-17
Auto Wake on S5	3-18
Wake on LAN	3-18
Boot Settings	3-19
Boot Type	3-19
PXE Boot to LAN	3-19
Add Boot Options	3-19
USB Boot	3-19
EFI Device First	3-20
Boot Delay Time	3-20
Legacy	3-20
Exit Settings	3-22
Exit Saving Changes	3-22
Save Change Without Exit	3-22
Exit Discarding Changes	3-22
Load Optimal Defaults	3-23
Load Custom Defaults	3-23
Save Custom Defaults	3-23
Discard Changes	3-23
Enable AMT	3-23
Use AMT	3-27
Upgrading the BIOS	3-27
<b>A. Safety Installation Instructions</b>	<b>A-1</b>

# Introduction

---

Thank you for purchasing a Moxa DA-820 industrial computer, a multi-functional embedded computer designed especially for IEC 61850-3 substation automation systems.

This manual covers hardware installation, connector interfaces, and BIOS setup of the DA-820. For software configuration and management, please refer to the user's manual for your operating system.

The following topics are covered in this chapter:

- **Overview**
- **Model Descriptions and Package Checklist**
- **Appearance**
- **Dimensions**
- **Features**
- **Hardware Block Diagram**
  - DA-820 Basic System
- **Hardware Specifications**

## Overview

The DA-820 computers are x86 platforms in a standard, 19-inch, 3U rack-mountable housing, with 2 VGA outputs, 4 Gigabit Ethernet ports, an internal CFast socket for OS storage, 2 RS-232/422/485 serial ports, and 6 USB ports.

With dual power supplies, 4 SDD/HDD slots, and a native PRP/HSR expansion module with specialized middleware, the DA-820 computers are designed for a wide variety of industrial automation applications to achieve maximum availability. In addition, the DA-820 computers comply with the IEC 61850-3 and IEC 60255 standards, guaranteeing system stability and reliability when used in a power industry application. As an added value, the DA-820 features a modular design with standard PCI and PCIe interfaces for tremendous integration and expansion flexibility. Users can add a variety of communication modules or graphics card to any of the 2 PCI slots, 3 PCIe x1 slots, and 1 PCIe x16 slot.

Wide temperature models of the DA-820 operate reliably in a -40 to 75°C operating temperature range with a high performance dual-core processor, offering an optimal solution for applications subjected to harsh environmental conditions.

The DA-820 is compliant with the IEC 60255 standard, which covers the protection of electrical relays in a smart substation. IEC 60255 is one of the most widely used standards for testing relays and protection equipment, and compliance ensures that the DA-820 will work reliably and seamlessly with IEDs (intelligent electronic devices) as a part of robust substation automation system.

## Model Descriptions and Package Checklist

The DA-820 Series includes the following models:

- **DA-820-C7-SP-HV-T:** Rackmount computer with Intel i7-3555LE, dual-core 2.5 GHz CPU, 100 to 240 VAC/VDC power supply, -40 to 75°C operating temperature (without CFast/RAM/OS)
- **DA-820-C7-DP-HV-T:** Rackmount computer with Intel i7-3555LE, dual-core 2.5 GHz CPU, 100 to 240 VAC/VDC power supply x 2, -40 to 75°C operating temperature (without CFast/RAM/OS)
- **DA-820-C7-SP-LV-T:** Rackmount computer with Intel i7-3555LE, dual-core 2.5 GHz CPU, 24 to 110 VDC power supply, -40 to 75°C operating temperature (without CFast/RAM/OS)
- **DA-820-C7-DP-LV-T:** Rackmount computer with Intel i7-3555LE, dual-core 2.5 GHz CPU, 24 to 110 VDC power supplies x 2, -40 to 75°C operating temperature (without CFast/RAM/OS)
- **DA-820-C8-SP-HV:** Rackmount computer with Intel i7-3612QE, quad-core 2.1 GHz CPU, 100 to 240 VDC power supply, -40 to 60°C (without CFast/RAM/OS)
- **DA-820-C8-DP-HV:** Rackmount computer with Intel i7-3612QE, quad-core 2.1 GHz CPU, 100 to 240 VDC power supplies x 2, -40 to 60°C operating temperature (without CFast/RAM/OS)
- **DA-820-C8-SP-LV:** Rackmount computer with Intel i7-3612QE, quad-core 2.1 GHz CPU, 24 to 110 VDC power supply, -40 to 60°C operating temperature (without CFast/RAM/OS)
- **DA-820-C8-DP-LV:** Rackmount computer with Intel i7-3612QE, quad-core 2.1 GHz CPU, 24 to 110 VDC power supplies x 2, -40 to 60°C operating temperature (without CFast/RAM/OS)

Each model ships with following additional items:

- Rackmount kit
- Documentation CD or DVD
- Quick installation guide (printed)
- Warranty card

**Optional Expansion Modules:**

- **DA-IRIG-B-S-02:** IRIG-B expansion module, PCI interface, 1 fiber IRIG-B in, 1 DB9M in/out, 1 DB9M out
- **DA-IRIG-B-S-04:** IRIG-B expansion module, PCI interface, 1 fiber IRIG-B in, 1 DB9M in/out, 3 DB9M out
- **DE-PRP/HSR:** PRP/HSR expansion module, PCIe interface
- **DE-GX02-SFP:** 2-port 1,000 Mbps fiber card, SFP slots x 2, PCIe interface (does not include SFP module)
- **DE-FX02-SFP:** 2-port 10/100 Mbps fiber card, SFP slots x 2, PCIe interface (does not include SFP module)



**ATTENTION**

Additional expansion modules are currently under development.

# Appearance

**Front View**

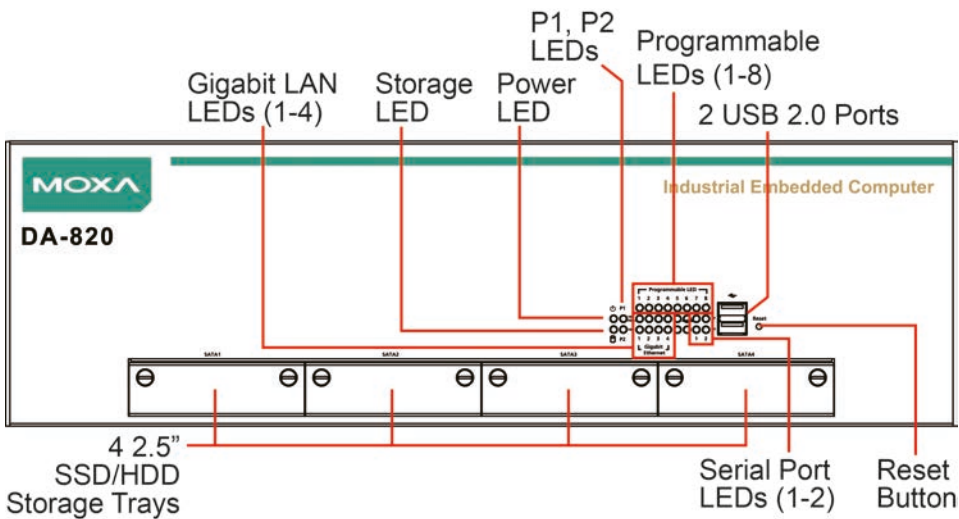

**Rear View**

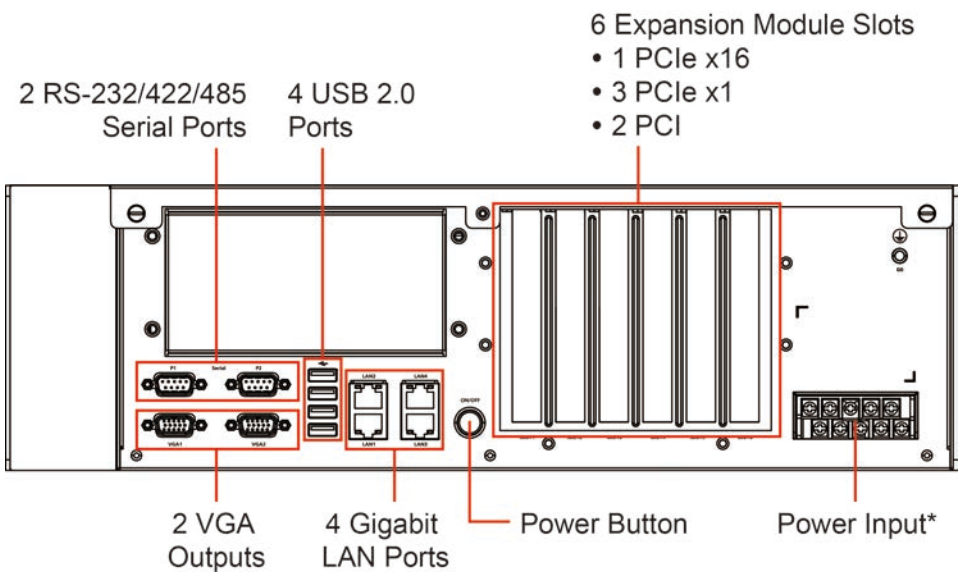

\*The power input supports two types of power supply (refer to the section "Connecting the Power" in Chapter 2 for details):  
 HV: 100 to 240 VAC/VDC  
 LV: 24 to 110 VDC

## Dimensions

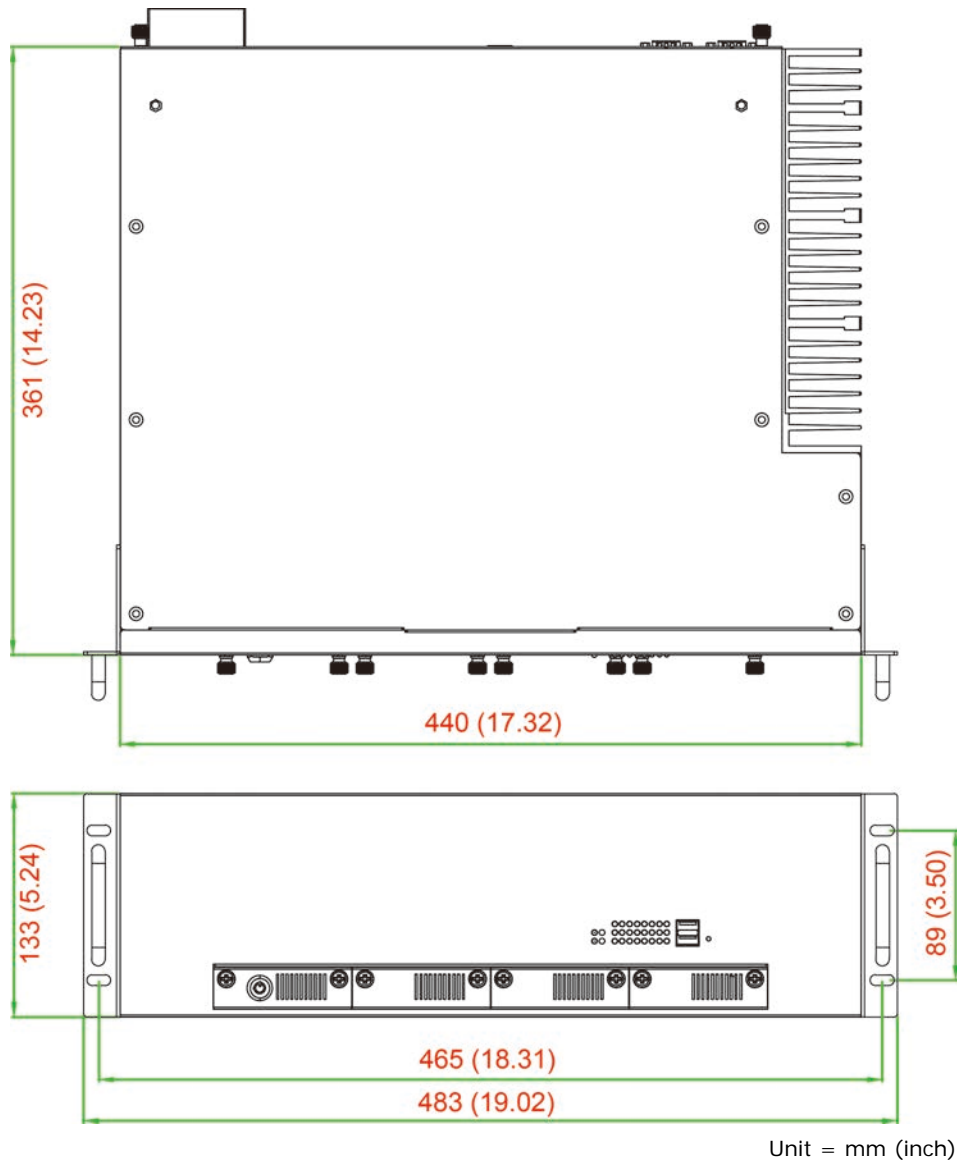

## Features

The DA-820 computer has the following features:

- Intel Core i7 dual/quad core processor with Intel QM77 Express chipset
- 2 x 204-pin SO-DIMM DDR3 sockets, supporting un-buffered ECC DDR3 memory at 1333 and 1600 MT/s, 16 GB max.
- 6 USB 2.0 ports for high speed peripherals
- 3 PCIe x1 slots and 2 PCI slots for expansion modules
- 1 PCIe x16 slot for an additional video card
- Highly reliable design, supporting dual power, RAID 0/1/5/10, and PRP/HSR technology (with PRP/HSR expansion module)
- Cybersecurity function
- IEC 61850-3 (general requirements for electrical substation automation, EMC Level 4, C3, Bm)
- IEEE 1613 compliant (environmental and testing requirements for communications networking devices in electric power substations)
- IEC 60255 compliant (measuring relays and protection equipment)

# Hardware Block Diagram

## DA-820 Basic System

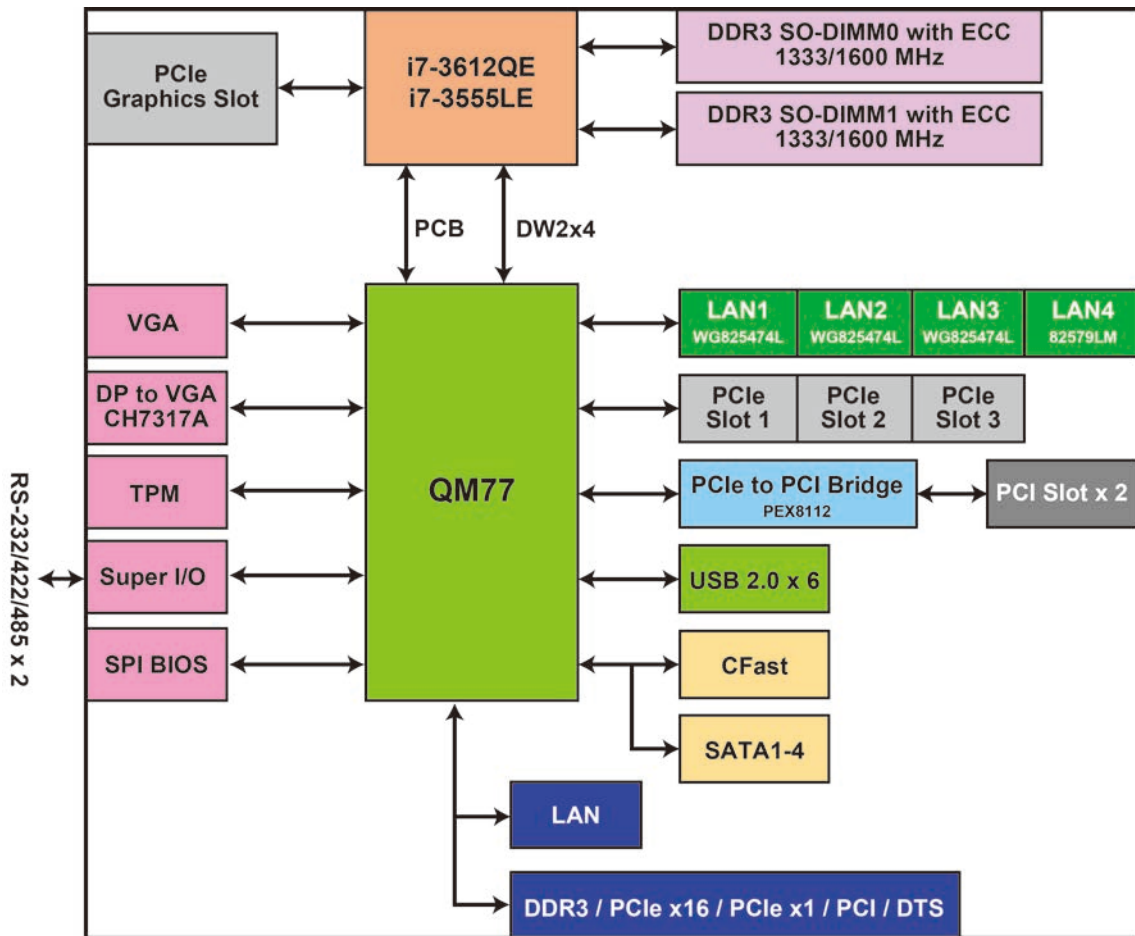

# Hardware Specifications

### Computer

#### CPU:

- DA-820-C7: Intel dual core i7-3555LE 2.5 GHz processor
- DA-820-C8: Intel quad core i7-3612QE 2.1 GHz processor

**OS\*:** 64-bit Debian 7 or 64-bit Windows Embedded Standard 7

\*The OS is optional; you may purchase Windows Embedded Standard 7 via CTOS, or download Debian 7 from our website.

**System Chipset:** QM77

**BIOS:** SPI Flash 64 Mbit BIOS, PCI Plug & Play, ACPI function support

**System Memory:** Max. 16 GB capacity (204-pin SO-DIMM x 2, each supporting un-buffered ECC DDR3 memory at 1333 and 1600 MT/s, 8 GB Max.)

#### USB:

- Rear panel: 4 USB 2.0 type A ports
- Front panel: 2 USB 2.0 type A ports

### Storage

**Built-in:** CFast socket onboard to store OS (CFast card needs to be purchased separately)

**Storage Expansion:** 4 SATA 2.0 interfaces, supporting RAID 0, 1, 5, 10, hot-swappable



## Display

**Graphics Controller:** Intel® HD Graphics 4000

**Display Interface:** 2 VGA outputs (DB15 female connector)

**Resolution:** CRT display mode with pixel resolution up to 2048 x 1536 at 75 Hz

## Ethernet Interface

**LAN:** 4 auto-sensing 10/100/1000 Mbps ports

- Ethernet 1 to 3: Intel 82574 Gigabit Ethernet Controller
- Ethernet 4: Intel 82579 Gigabit Ethernet controller supporting Intel AMT technology

**Magnetic Isolation Protection:** 1.5 kV built-in

## Serial Interface

**Serial Standards:** 2 RS-232/422/485 ports (DB9 male)

## Serial Signals

**RS-232:** TxD, RxD, DTR, DSR, RTS, CTS, DCD, GND

**RS-422:** TxD+, TxD-, RxD+, RxD-, GND

**RS-485-4w:** TxD+, TxD-, RxD+, RxD-, GND

**RS-485-2w:** Data+, Data-, GND

## LEDs

**System:** Power, Storage

**Gigabit LAN:** 100M x 4, 1000M x 4

**Serial:** TX/RX

**Programmable:** LED x 8

## Switches and Buttons

**Power Switch:** on/off (on rear panel)

## Physical Characteristics

**Housing:** SECC sheet metal (1 mm)

**Weight:** 6 kg

**Dimensions:** 361 x 440 x 133 mm (14.23 x 17.32 x 5.24 in) (without rackmount ears)

**Mounting:** Standard 19-inch rackmount

## Environmental Limits

**Operating Temperature:**

- DA-820-C8: -40 to 60°C (-40 to 140°F)
- DA-820-C7: -40 to 75 °C (-40 to 167°F)

**Storage Temperature:** -40 to 85°C (-40 to 185°F)

**Ambient Relative Humidity:** 5 to 95% (non-condensing)

**Anti-vibration:** 2 Grms @ IEC-68-2-34, random wave, 5-500 Hz, 1 hr per axis

**Anti-shock:** 20 g @ IEC-68-2-27, half sine wave, 11 ms

## Power Requirements

**Input Range:**

- High Voltage: 100 to 240 VAC/VDC, 50/60 Hz, 1 A
- Low Voltage: 24 to 110 VDC, 4.7 A

**Multiple Power Supplies:**

- SP: Single power supply
- DP: Dual power supplies

**Power Consumption:** 60 W

## Standards and Certifications

**Safety:** LVD, UL, cUL

**Electrical Substation:** IEC 61850-3, IEC 60255, IEEE 1613

**Protection Relay:** IEC 60255

**EMC:** FCC, CE (Class A)

**Green Product:** RoHS, CRoHS, WEEE

**Reliability**

**Alert Tools:** Built-in buzzer and RTC (real-time clock) with lithium backup battery

**Automatic Reboot Trigger:** Built-in WDT (watchdog timer) supporting 1-255 level time interval system reset, software programmable

**Warranty**

**Warranty Period:** 3 years

**Details:** See [www.moxa.com/warranty](http://www.moxa.com/warranty)

## Hardware Installation

---

The DA-820 embedded computers are compact and rugged, making them suitable for industrial applications. The LED indicators allow users to monitor performance and identify trouble spots quickly, and multiple ports are provided for connecting a variety of different devices. The DA-820 embedded computers come with a reliable and stable hardware platform that lets you devote the bulk of your time to application development. This chapter describes hardware installation and connector interfaces of the DA-820 embedded computers.

The following topics are covered in this chapter:

- ❑ **Wiring Requirements**
- ❑ **Connecting the Power**
- ❑ **Wiring the Power Inputs**
- ❑ **HIPOT (Dielectric Strength) Testing**
- ❑ **Reset Button**
- ❑ **LED**
- ❑ **Connecting to a Display**
- ❑ **Connecting USB Devices**
- ❑ **Gigabit LAN Ports**
- ❑ **Upgrading the Memory Module**
- ❑ **Installing a CFast Card**
- ❑ **Installing SATA Hard Disks**

# Wiring Requirements

The following common safety precautions should be observed before installing any electronic device:

- Power wires and communication/signal wires should be routed through separate paths. If power and communication/signal wires must cross paths, make sure the wires are perpendicular at the intersection point.
 

**NOTE:** Do not run signal or communication wiring and power wiring in the same wire conduit. To avoid interference, wires with different signal characteristics should be routed separately.
- Use the type of signal transmitted through a wire to determine which wires should be bundled together and which kept separate. The rule of thumb is that wiring that carries similar electrical signals can be bundled together.
- When necessary, we strongly advise labeling the wiring for all devices in the system.



**ATTENTION**

Do not run signal or communication wiring and power wiring in the same wire conduit. To avoid interference, wires with different signal characteristics should be routed separately.



**ATTENTION**

**Safety First!**

Be sure to disconnect the power cord before installing and/or wiring your device.

**Electrical Current Caution!**

Calculate the maximum possible current in each power wire and common wire. Observe all electrical codes dictating the maximum current allowable for each wire size.

If the current goes above the maximum rating, the wiring could overheat, causing serious damage to your equipment.

**Temperature Caution!**

Be careful when handling the unit. When the unit is plugged in, the internal components generate heat, and consequently the outer casing may feel hot to the touch.

# Connecting the Power

To power on the DA-820 embedded computer, connect the power line to the DA-820's power connector (located on the right side of the rear panel) using the power cord shipped with the product, and then turn on the power switch. If the power is properly supplied, the Power LED will light up first, and then the Storage LED will start blinking when the Flash Disk Module is accessed during boot up. It takes about 30 to 60 seconds for the operating system to boot up.

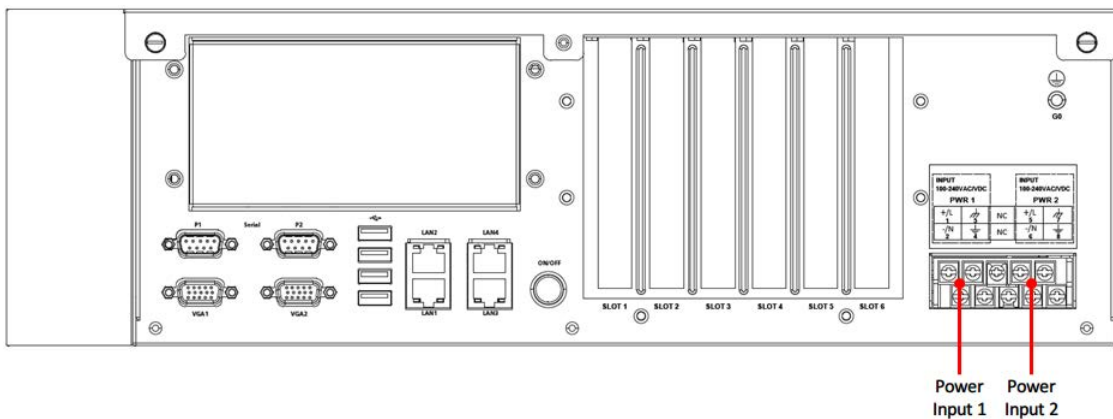

# Wiring the Power Inputs

Refer to the following diagrams and table for a detailed description of the power input wiring. The terminal numbers referred to in the table are shown in the leftmost diagram below.

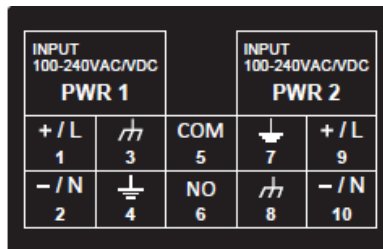
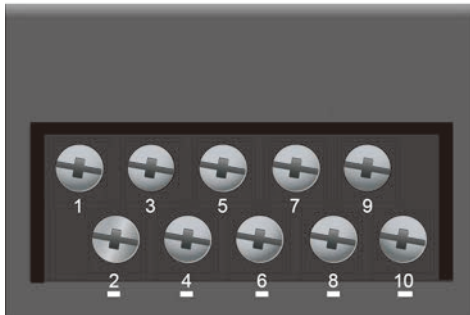

Terminal Number	Description	Note
1	PWR1 Line	<b>PWR1 Line (+)</b> is connected to the Line terminal for the AC power source.
2	PWR1 Neutral	<b>PWR1 Neutral (-)</b> is connected to the Neutral terminal for the AC power source.
3	PWR1 Surge Ground	<b>PWR1 Surge Ground</b> is connected to the <b>Chassis Ground</b> via a jumper on the terminal block. <b>Surge Ground</b> is used as the ground conductor for all surge and transient suppression circuitry. <i>NOTE: Surge Ground must be disconnected from Chassis Ground during HIPOT (dielectric strength) testing.</i>
4	Chassis Ground	<b>Chassis Ground</b> is connected to the Safety Ground terminal for AC inputs. Chassis ground connects to both power supply surge grounds via a removable jumper.
5	NC	No function
6	NC	No function
7	Chassis Ground	<b>Chassis Ground</b> is connected to the Safety Ground terminal for AC inputs. Chassis ground connects to both power supply surge grounds via a removable jumper.
8	PWR2 Surge Ground	<b>PWR2 Surge Ground</b> is connected to the Chassis Ground via a jumper on the terminal block. Surge Ground is used as the ground conductor for all surge and transient suppression circuitry. <i>NOTE: Surge Ground must be disconnected from Chassis Ground during HIPOT (dielectric strength) testing.</i>
9	PWR2 Line	<b>PWR2 Line (+)</b> is connected to the Line terminal for the AC power source.
10	PWR2 Neutral	<b>PWR2 Neutral (-)</b> is connected to the Neutral terminal for the AC power source.

### For AC Power Input

1. PWR1 Line should be connected to AC (Line).
2. PWR1 Neutral should be connected to AC (Neutral).

3. Surge Ground is connected to the Chassis Ground via a braided cable or other appropriate grounding wire. Surge Ground is used as the ground conductor for all surge and transient suppression circuitry internal to the protection board.
4. Chassis Ground should be connected to the AC Ground terminal.

### Alternating Current (AC), Single Power



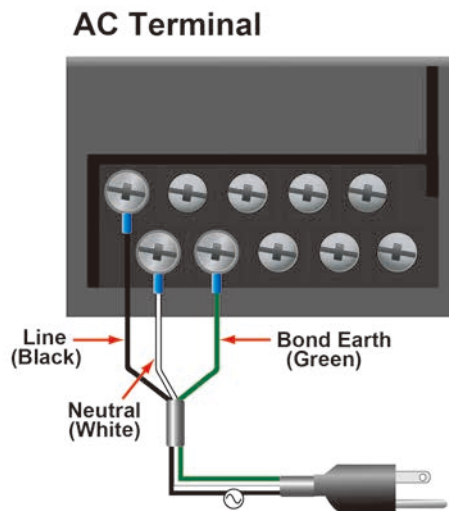
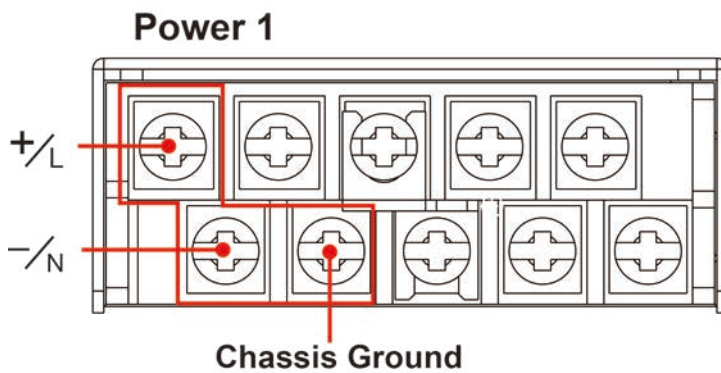

Models: DA-820-C8-SP-HV, DA-820-C7-SP-HV-T

INPUT 100-240VAC/VDC				
PWR 1				
+ / L 1	 3	COM 5	7	9
- / N 2	 4	NO 6	8	10



### Alternating Current (AC), Dual Power

Models: DA-820-C8-DP-HV, DA-820-C7-DP-HV-T

INPUT 100-240VAC/VDC PWR 1			INPUT 100-240VAC/VDC PWR 2		
+ / L 1	 3	COM 5	 7	+ / L 9	
- / N 2	 4	NO 6	 8	- / N 10	

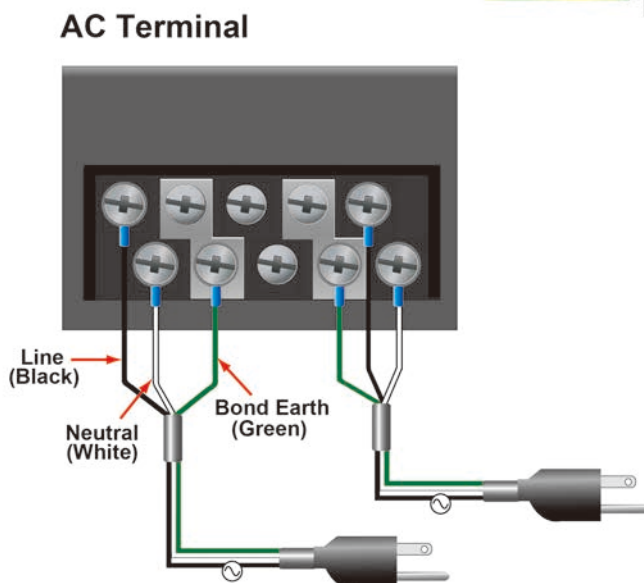
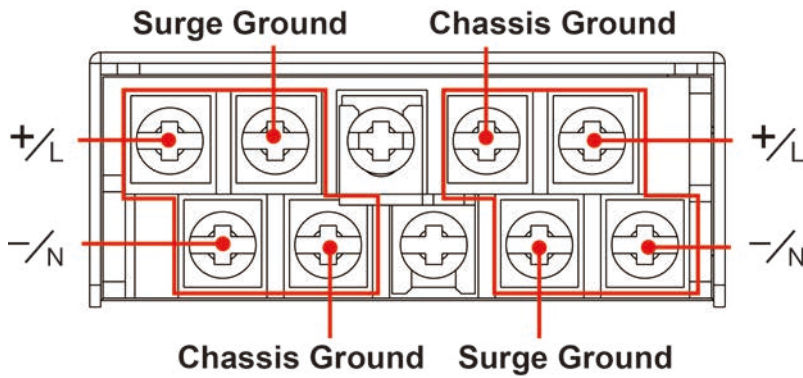

### Direct Current (DC), Single Power

Models: DA-820-C8-SP-HV, DA-820-C8-SP-LV, DA-820-C7-SP-HV-T, DA-820-C7-SP-LV-T

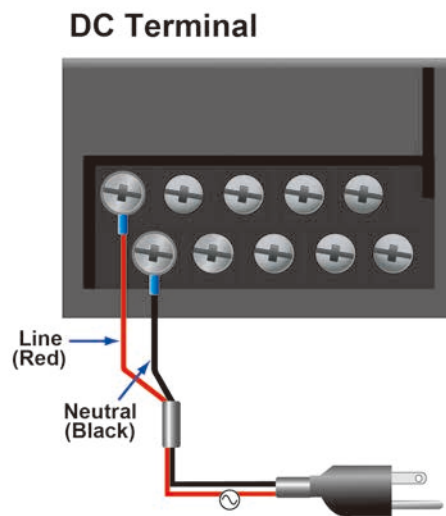
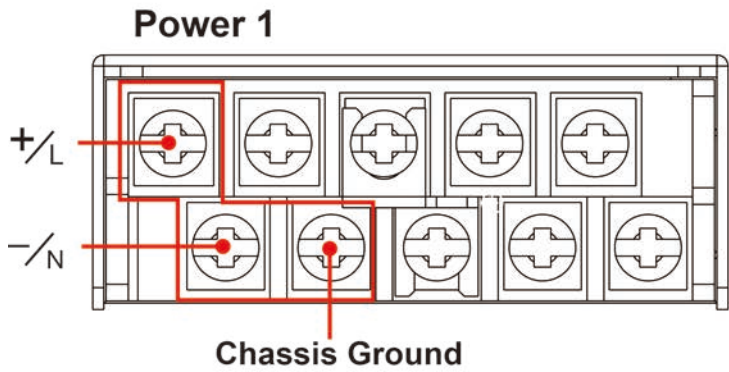
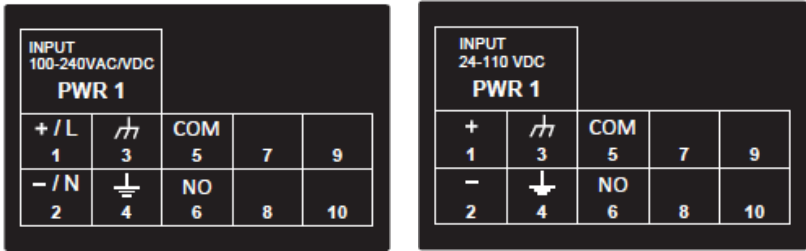



### Direct Current (DC), Dual Power

Models: DA-820-C8-DP-HV, DA-820-C8-DP-LV, DA-820-C7-DP-HV-T, DA-820-C7-DP-LV-T

INPUT 100-240VAC/VDC PWR 1			INPUT 100-240VAC/VDC PWR 2		
+ / L 1		COM 5		+ / L 9	
- / N 2		NO 6		- / N 10	

INPUT 24-110 VDC PWR 1			INPUT 24-110 VDC PWR 2		
+ 1		COM 5		+ 9	
- 2		NO 6		- 10	



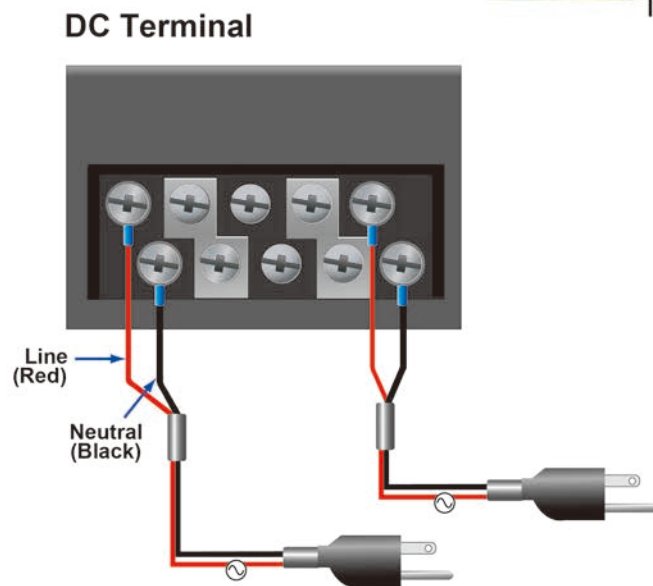
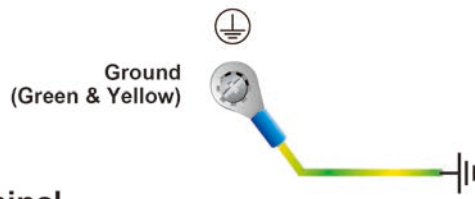
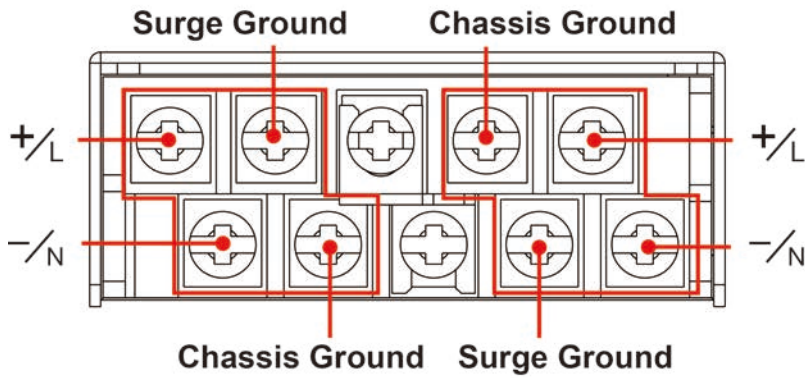

**ATTENTION**

1. Equipment must be installed according to the applicable country wiring codes.
2. Surge Ground **MUST** be disconnected from the Chassis Ground during HIPOT (dielectric strength) testing.
3. All line-to-ground transient energy is shunted to the Surge Ground terminal. In cases where users require the inputs to be isolated from the ground, remove the ground braid between Surge and Chassis Ground. Note that all line-to-ground transient protection circuitry will be disabled.

## HIPOT (Dielectric Strength) Testing

Before performing the HIPOT test, you **MUST** remove the jumpers and disconnect the braided ground cable. Doing so can prevent the transient/surge suppression circuitry (which is connected to Surge Ground) from being activated during the HIPOT test.

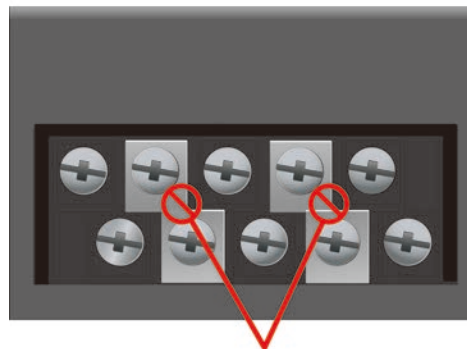

Remove Jumpers

When finished, press the Power Switch button to start the system. It will take about 30 to 60 seconds for your operating system to boot up.

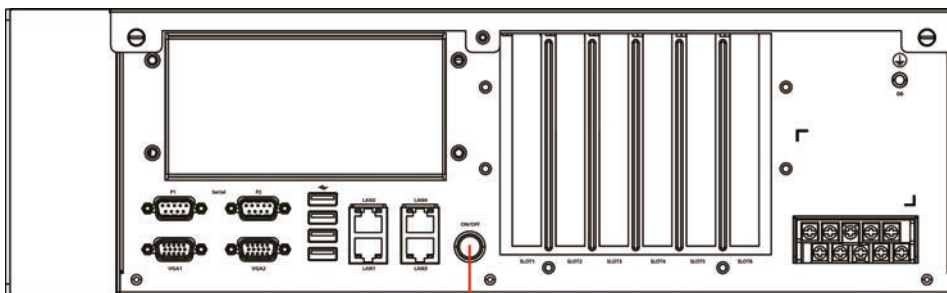

Power Switch

# Reset Button

Pressing the Reset button initiates a hardware warm reboot. The button plays the same role as a desktop PC's reset button. After pressing the reset button, the system will reboot automatically. During normal use, you should NOT use the Reset Button. You should only use this button if the software is not working properly. To protect the integrity of data being transmitted or processed, you should always reset the system from the operating system with the software reboot function.

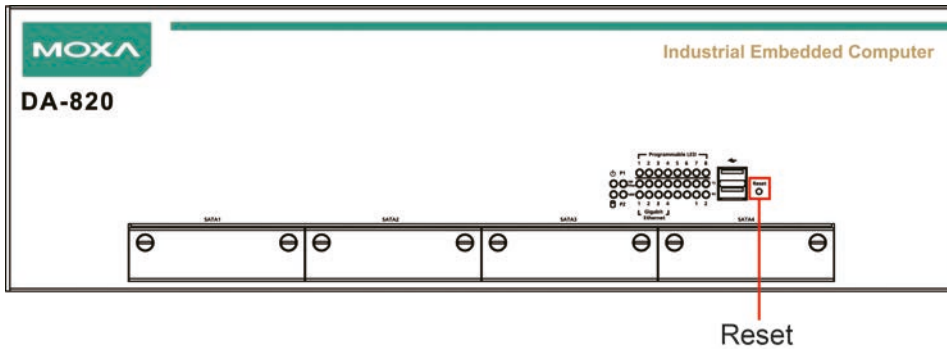

# LED

There are 28 LED indicators on the front panel. Information about each LED is given in the following table.

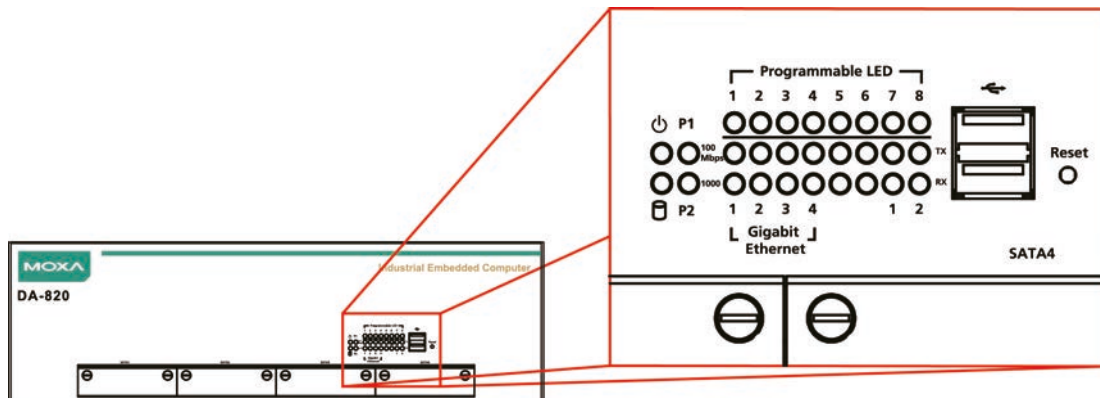

LED	Color	Description
Power	Green	Power is on
	Off	No power input or power error exists
Storage	Yellow/Blinking	Data is being written to or to read from the storage unit
	Off	Storage unit is idle
P1 (Non-functional for single power supply)	Off	The 1st power in on
	Red	Error in the 2nd power supply
P2 (Non-functional for single power supply)	Off	The 2nd power is on
	Red	Error in the 1st power supply
Gigabit LAN LEDs 1-4	Green	100 Mbps Ethernet mode
	Orange	1000 Mbps (Gigabit) Ethernet mode
Serial Port 1/2	Green	Tx
	Yellow	Rx
Programmable 1-8	Green/Blinking	1-8 programming action is in process

# Connecting to a Display

Your DA-820 embedded computer comes with two D-Sub 15-pin female connectors to connect to the VGA monitor. Be sure to disconnect the power before you connect or disconnect the monitor cable.

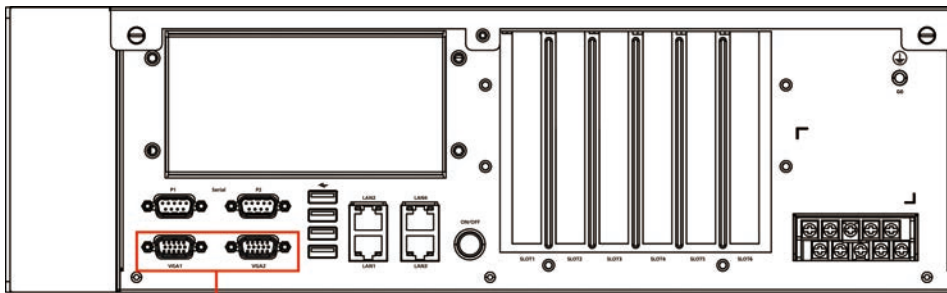

2 VGA Outputs

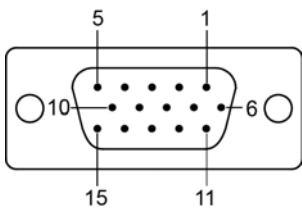

Pin No.	Signal Definition
1	RED
2	GREEN
3	BLUE
4	NC
5	GND
6	GND
7	GND
8	GND
9	VCC
10	GND
11	NC
12	DDC Data
13	HSYNC
14	VSYSN
15	DDC Clock

# Connecting USB Devices

The DA-820 embedded computer has six USB 2.0 ports, with two ports on the front panel and the other four on the rear panel. All of the ports are UHCI, Rev 2.0 compliant and support Plug & Play and hot swapping. These ports can be used to connect USB devices, such as a keyboard, mouse, USB flash disk, and USB CD-ROM. In addition, both USB ports support system boot up, which can be activated by modifying the BIOS settings. See **Chapter 3: BIOS Setup** for details.



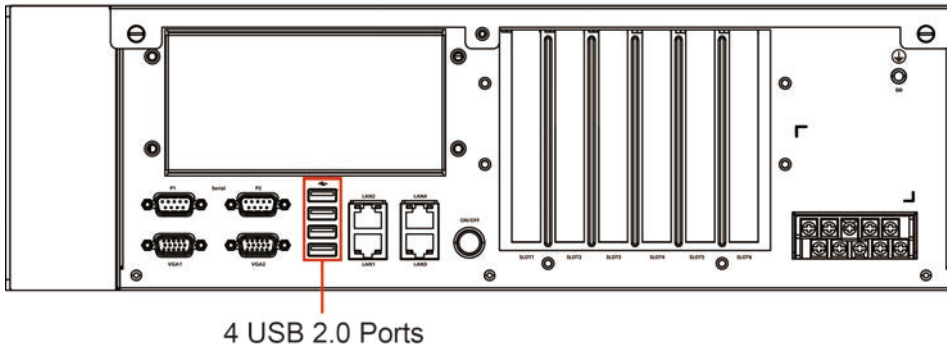

## Gigabit LAN Ports

The DA-820 Basic System has 4 Gigabit LAN ports. When a LAN cable is properly connected, the LEDs on the RJ45 connectors will glow to indicate a proper connection.

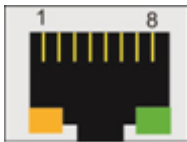

Pin	10/100 Mbps	1000 Mbps
1	Tx+	TRD(0)+
2	Tx-	TRD(0)-
3	Rx+	TRD(1)+
4	–	TRD(2)+
5	–	TRD(2)-
6	Rx-	TRD(1)-
7	–	TRD(3)+
8	–	TRD(3)-

LED	Color	Description
Gigabit LAN LEDs 1-4	Green	100 Mbps Ethernet mode
	Orange	1000 Mbps (Gigabit) Ethernet mode

The default IP addresses and netmasks of the Gigabit LAN ports are as follows:

	Default IP Address	Netmask
<b>LAN 1</b>	192.168.3.127	255.255.255.0
<b>LAN 2</b>	192.168.4.127	255.255.255.0
<b>LAN 3</b>	192.168.5.127	255.255.255.0
<b>LAN 4</b>	192.168.6.127	255.255.255.0

**NOTE** W7E models use DHCP by default to obtain IP addresses.

# Upgrading the Memory Module

The DA-820 embedded computer supports 2 ECC registered DDR3 1333/1600 SODIMM modules, for up to 16 GB of memory (2 slots, each with 8 GB). To upgrade the SDRAM memory module, follow these instructions:

1. Disconnect the DA-820 from its power source.
2. Unfasten the screws on the back of the computer, and then take off the upper cover.



3. Find the location of the SDRAM memory socket.

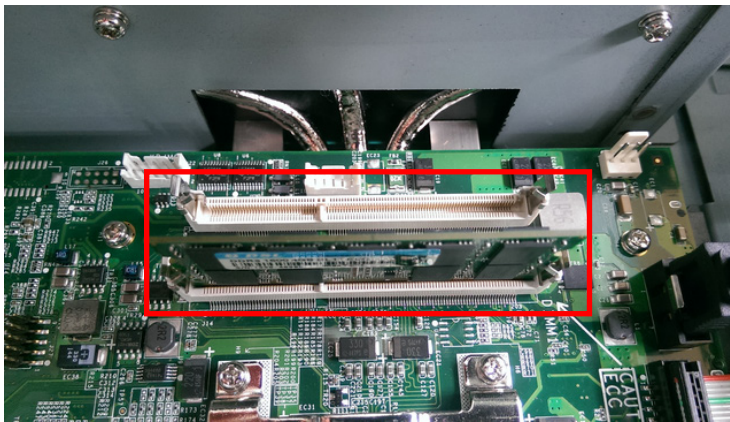

4. If a memory module is already installed in the socket, push the two fasteners to free and then remove the module. Insert the new memory module into the socket, making sure you insert the SDRAM in the correct direction. Push down the memory module, making sure that the two fasteners snap in place and are holding the module firmly.



5. When finished, replace the upper cover of the computer and fasten the screws.

# Installing a CFast Card

The DA-820 embedded computer comes with a CFast socket. To insert a CFast card, follow these instructions.

1. Disconnect the DA-820 from its power source.
2. Unfasten the screws on the back of the computer, and then take off the upper cover.



3. Find the location of the CFast socket.

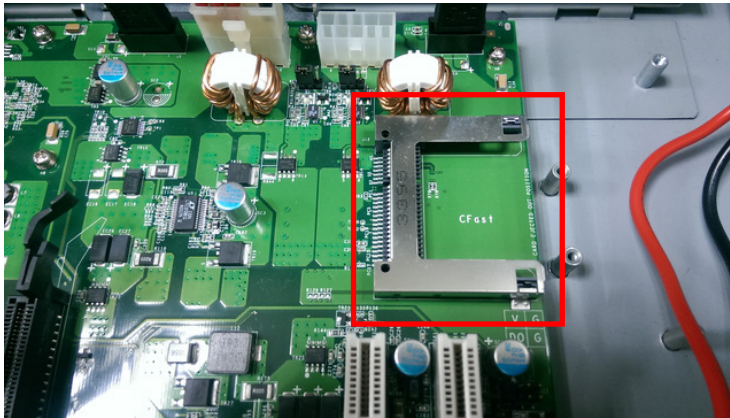

4. Insert the CFast card into the socket.



5. When finished, restore the upper cover of the computer and fasten the screws.



## ATTENTION

The DA-820 rackmount computer does not support the CFast hot swap and PnP (Plug and Play) functions. It is necessary to remove power source first before inserting or removing the CFast card.

# Installing SATA Hard Disks

The DA-820 comes with four SATA slots that allow users to install 2.5" SATA HDD/SSD in the computer. Follow these steps to install a SATA disk.

**Step 1:** Loosen screws from each of the four SATA slots (SATA1 is used to illustrate).



**Step 2:** Remove the SATA HDD Tray from the computer itself.

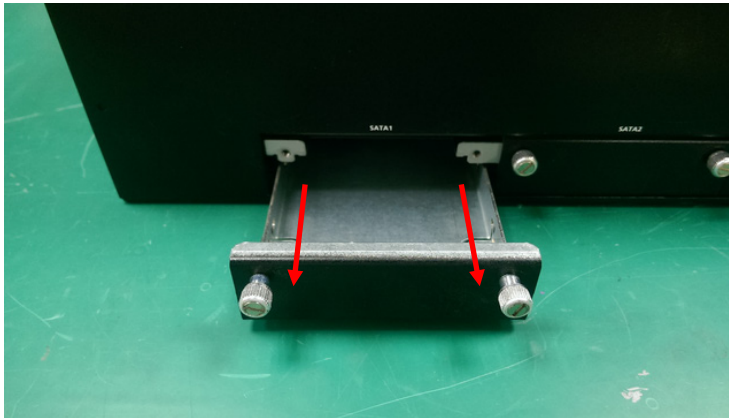

**Step 3:** Place the SSD/HDD in the tray as shown, and then flip the tray over to fasten the screws.





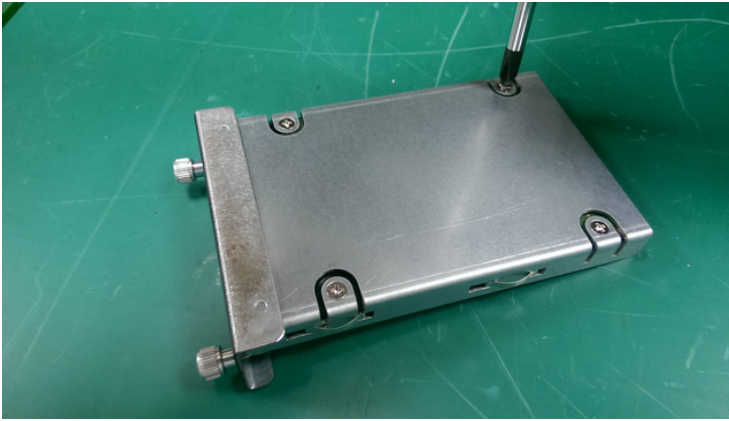

**Step 4:** Insert the SATA Tray into original SATA slot and fasten the screws.

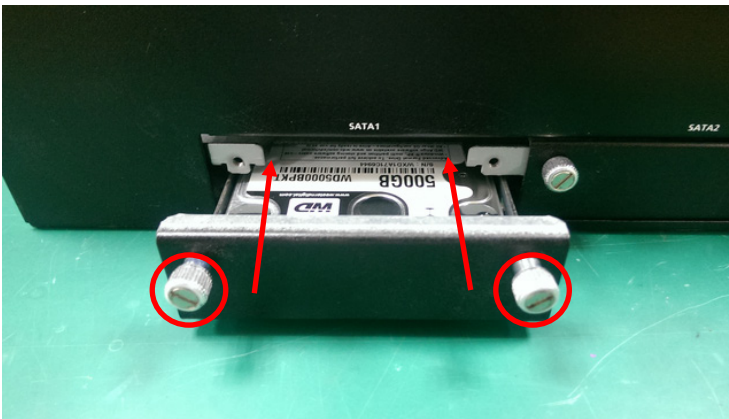

## BIOS Setup

---

This chapter describes the BIOS settings of the DA-820 computer. The BIOS is a set of input/output control routines for peripherals, and is used to initialize system peripherals before the operating system is loaded. The BIOS setup allows the user to modify the system configurations of these peripherals' basic input/output.

The following topics are covered in this chapter:

### ❑ Entering the BIOS Setup

#### ❑ Main Information

#### ❑ Advanced Settings

- Boot Configuration
- HDC Configuration
- Video Configuration
- PCI Express Graphics
- Chipset Configuration
- Active Management Technology Support
- PCI Express Configuration
- Hardware Monitor
- SMART RECOVERY Info

#### ❑ Security Settings

- TPM Status
- TPM Operation
- TPM Force Clear
- Set Supervisor Password

#### ❑ Power Settings

- Turbo Mode
- TXT
- Auto Wake on S5
- Wake on LAN

#### ❑ Boot Settings

- Boot Type
- PXE Boot to LAN
- Add Boot Options
- USB Boot
- EFI Device First
- Boot Delay Time
- Legacy

### ❑ Exit Settings

- Exit Saving Changes
- Save Change Without Exit
- Exit Discarding Changes
- Load Optimal Defaults
- Load Custom Defaults
- Save Custom Defaults
- Discard Changes

### ❑ Enable AMT

### ❑ Use AMT

### ❑ Upgrading the BIOS

## Entering the BIOS Setup

To enter the BIOS setup utility, press the "F2" key while the system is booting up. The main **BIOS Setup** screen will appear. Five options will be available:

- **Continue:** Continue to boot up
- **Boot Manager:** Select the device for booting up
- **Boot From File:** Select the UEFI boot up file
- **SCU:** Enter the BIOS configuration menu
- **MEBx:** Enter the AMT configuration menu

Select **SCU** to enter the **BIOS configuration**.

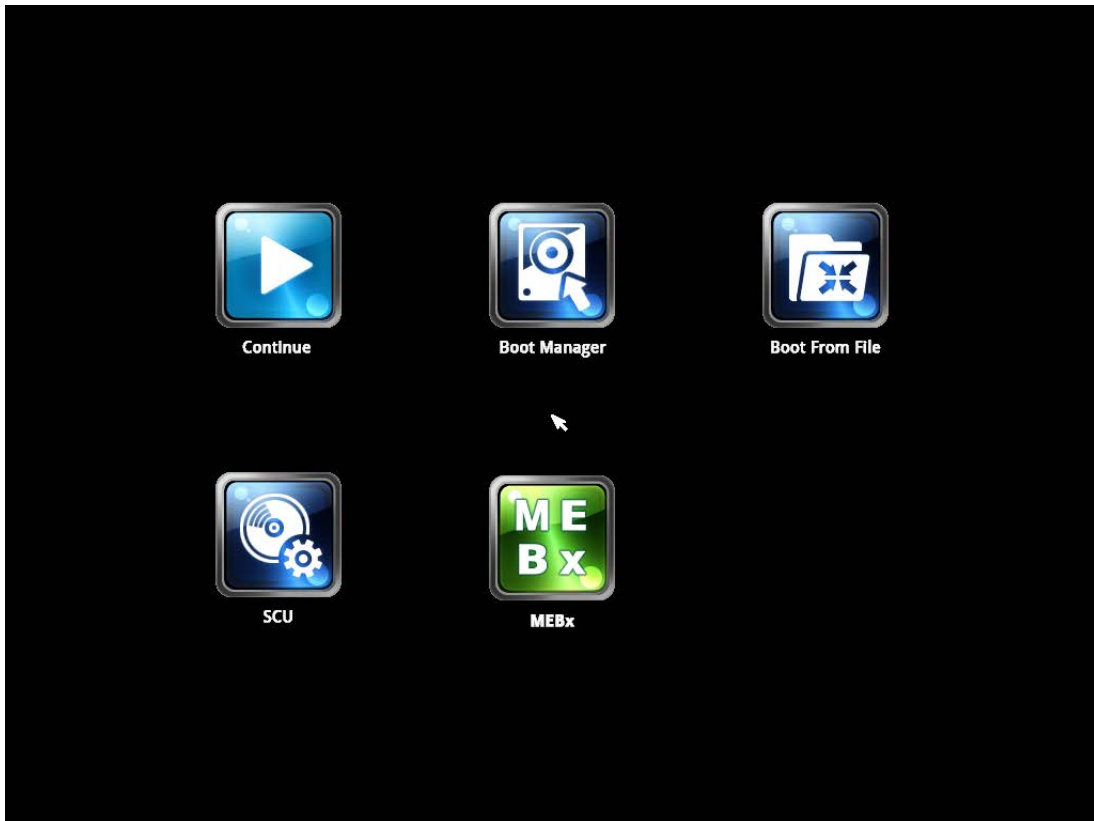

When you enter SCU, a basic description of each function key is listed at the bottom of the screen. Refer to these descriptions to learn how to use them.

<b>F1</b>	<b>General Help</b>	<b>↑ ↓ .</b>	<b>Select Item</b>
<b>F5/ F6</b>	<b>Change Values</b>	<b>← →</b>	<b>Select Menu</b>
<b>F9</b>	<b>Setup Defaults</b>	<b>ESC</b>	<b>Exit</b>
<b>F10</b>	<b>Save and Exit</b>	<b>EN TER</b>	<b>Select or go to Submenu.</b>

The BIOS configuration screen will be shown when you enter the SCU option, as shown in the following figure.

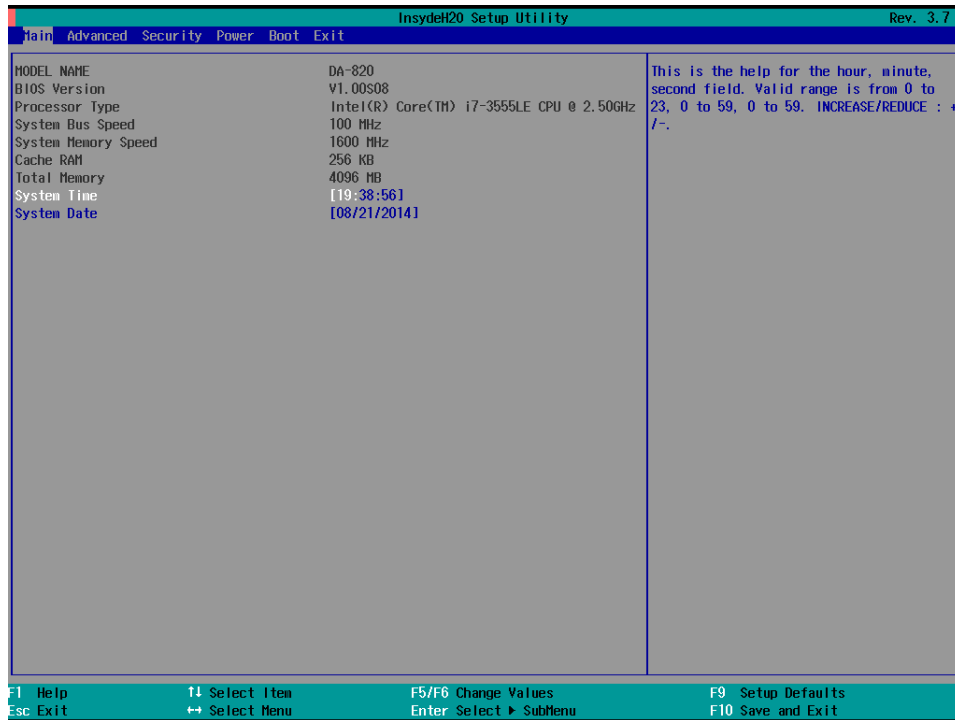

Note that the **Processor Type** information for will vary depending on which model you purchased.

## Main Information

The main page indicates the system information, such as model name, BIOS version, and CPU type. Users can view the basic system hardware information on this page.

## Advanced Settings

The “Advanced Features” screen will appear when choosing the “Advanced” item from the main menu.

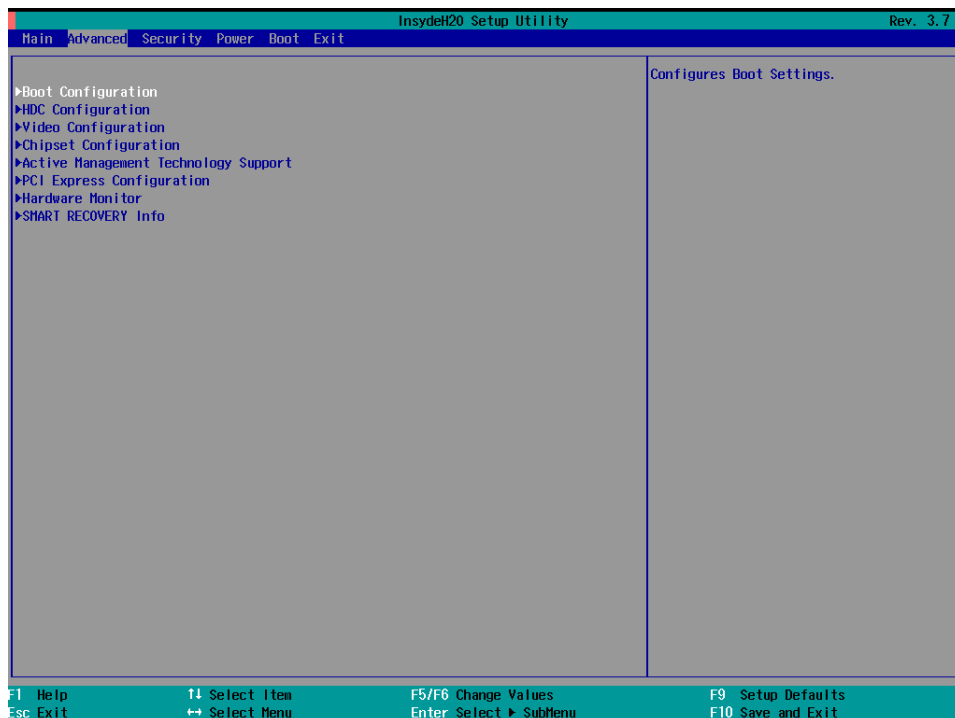

## Boot Configuration

This item allows users to configure the default value of Numlock.  
Options: On (default), Off.

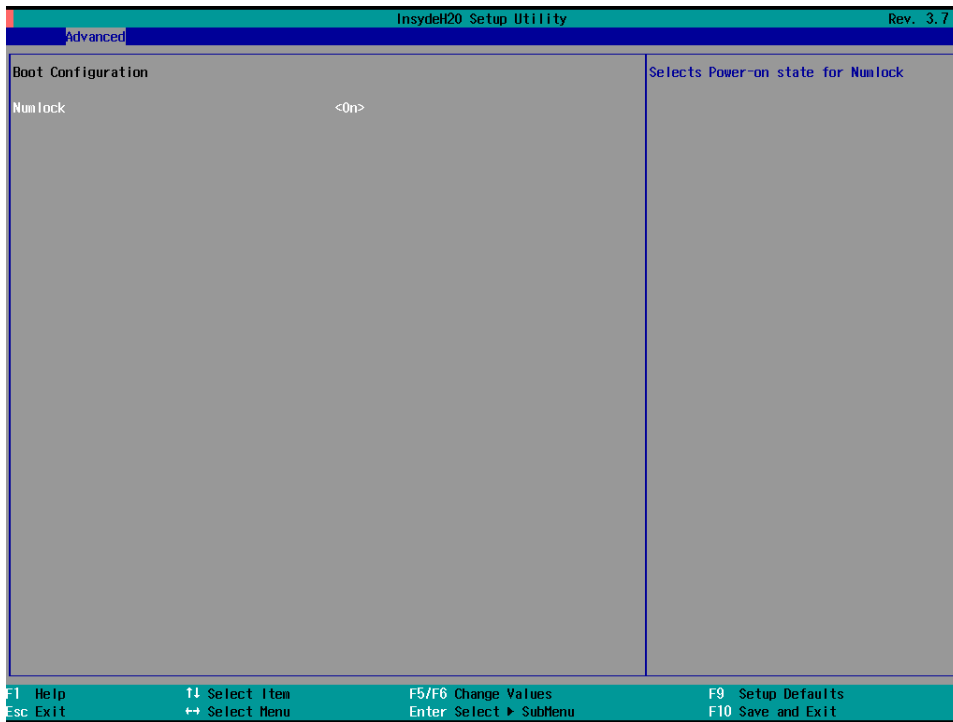

## HDC Configuration

The host drive controller can be configured for IDE (legacy default) or AHCI mode. When the legacy IDE mode is selected, the following screen will appear.

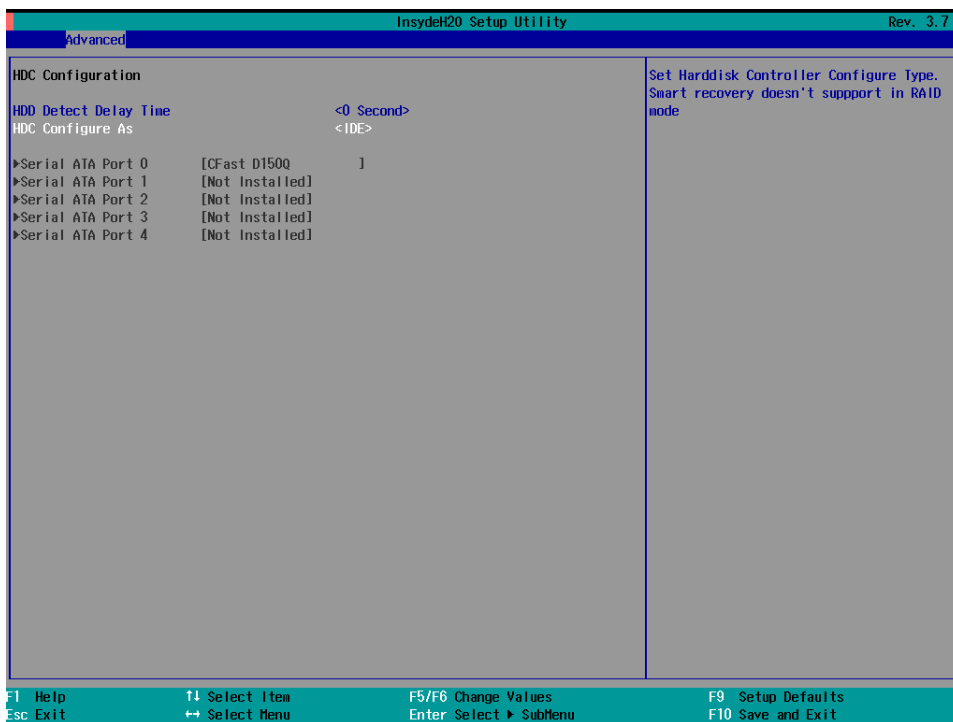

## Serial ATA Port <0 to 4>

This setting allows the user to display information about the installed drives.

## AHCI SALP

AHCI SALP will only appear when AHCI or RAID mode is selected. This item allows you to enable aggressive **link power management** (SALP) in AHCI/RAID. SALP enables the host bus adapter to conserve power by directly detecting when a SATA drive is no longer processing information and then immediately shifting it into suspended or sleep modes without waiting for software processes to initiate power-down processes.

Options: Enabled (default), Disabled

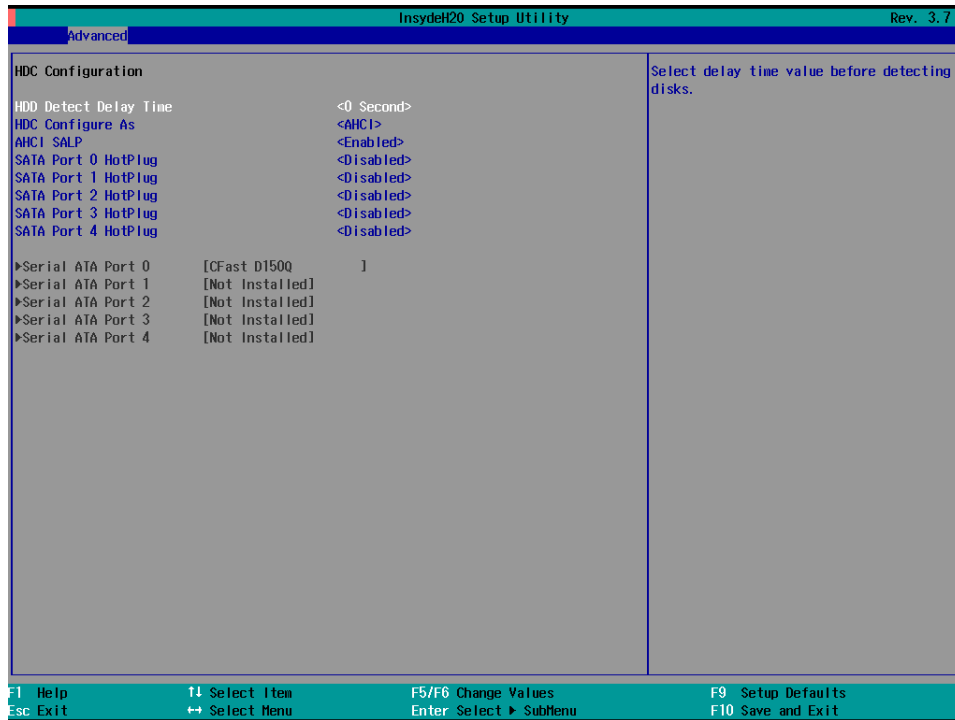

## SATA Port <0 to 4> - HotPlug

This item allows you to enable/disable hotplug capabilities (the ability to remove the drive while the computer is running) for installed storage drives.

Options: Disabled (default), Enabled

# RAID

Set HDC configuration as "RAID" to enable redundant array of inexpensive disks technology. The DA-820 supports RAID levels 0, 1, 5, 10, and Intel Rapid Recovery Technology.

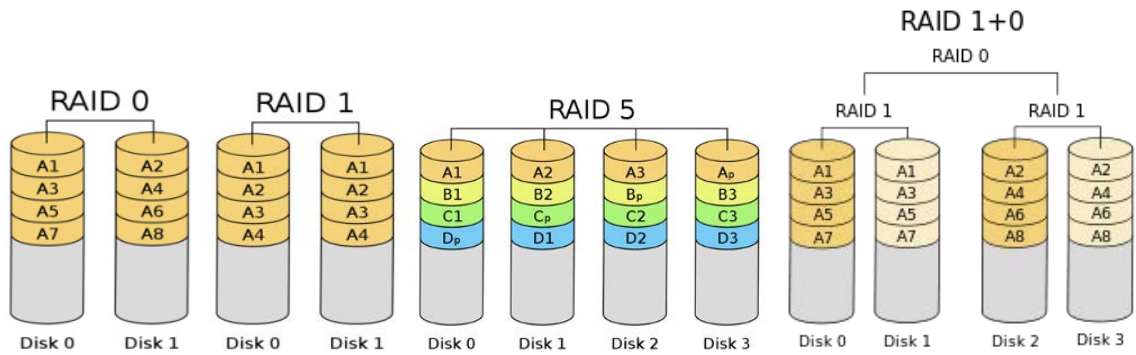

These figures were obtained from Wikipedia. Please refer to [http://en.wikipedia.org/wiki/Standard\\_RAID\\_levels](http://en.wikipedia.org/wiki/Standard_RAID_levels) for details.

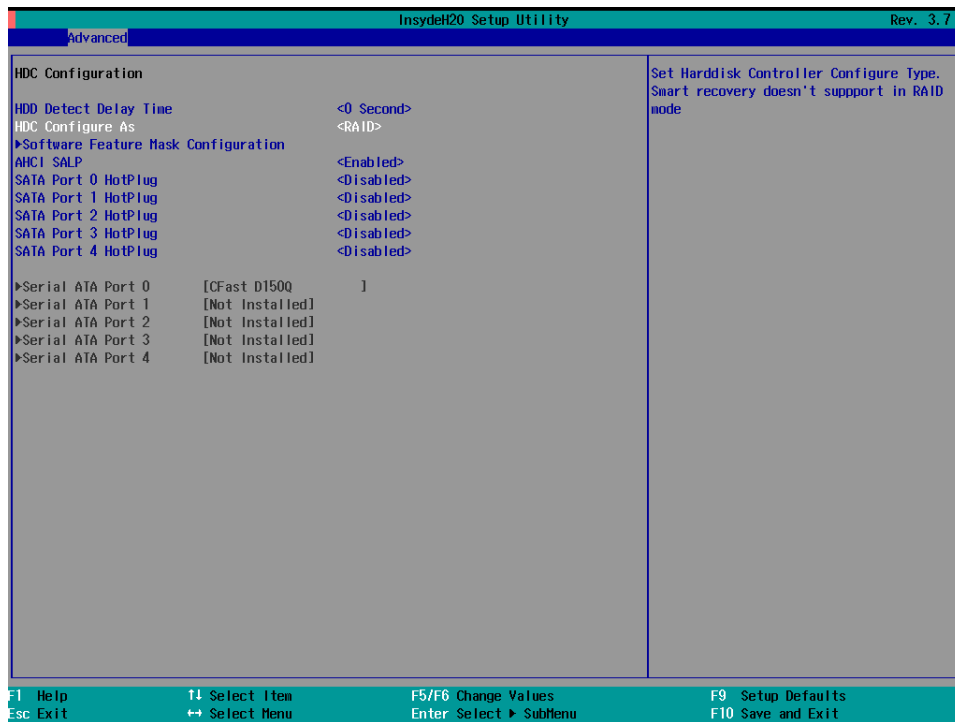

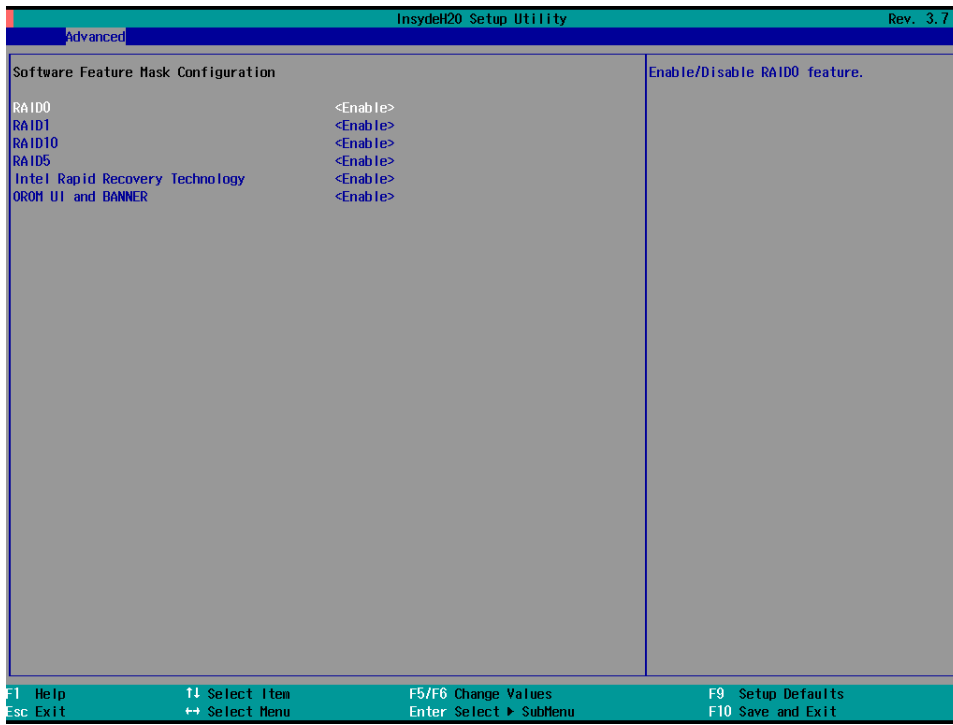

**NOTE** Smart Recovery is not supported under RAID mode.

## Video Configuration

This item allows you to configure the built-in Internal Graphics Device or external PCI Express Graphics card.

Options: IGFX (default), PEG

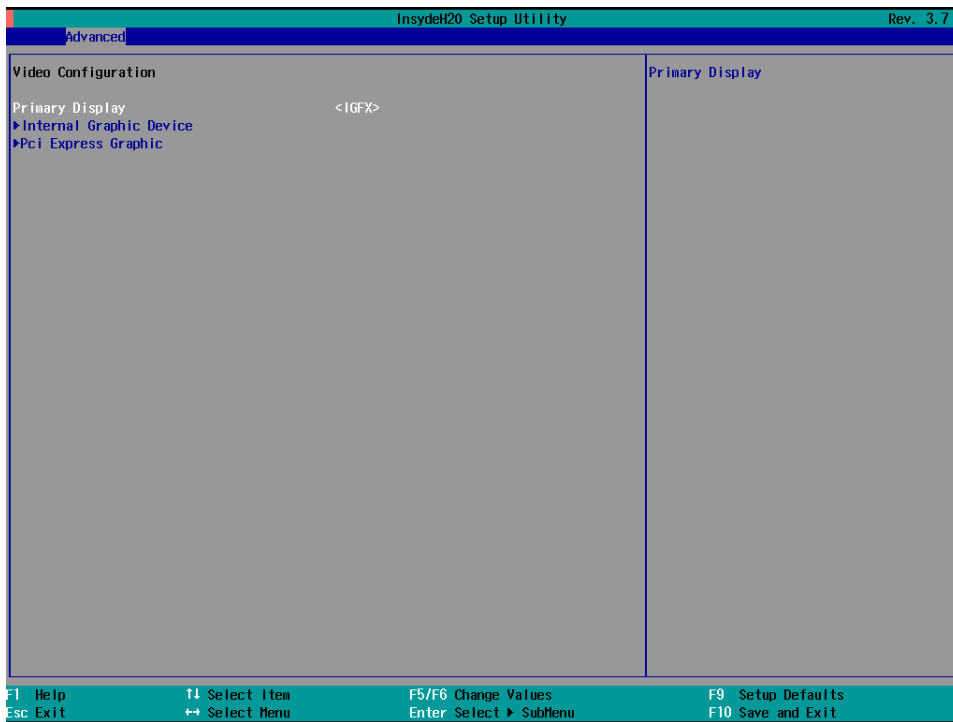



## Internal Graphics Device

This option allows you to enable/disable the internal graphics device.

Options: Enabled (default), Disabled

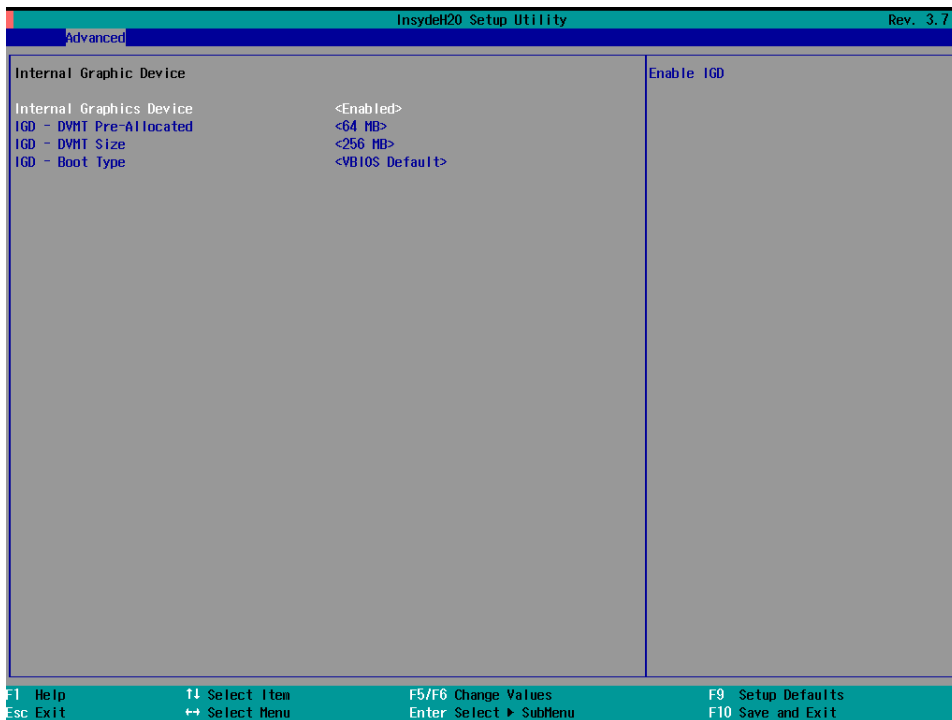

### IGD—DVMT Pre-Allocated

This item allows you to configure pre-allocated memory capacity for the IGD. Pre-allocated graphics memory is invisible to the operating system.

Options: 64 MB (default), 32 MB, 96 MB, 128 MB, 256 MB, 512 MB

**DVMT** is a BIOS solution where “the optimum amount of memory is dynamically allocated and de-allocated as needed for balanced graphics and system performance, through Intel® Direct AGP and a highly efficient memory utilization scheme.” DVMT ensures the most efficient use of available system memory resources for maximum 2D/3D graphics performance.

### IGD—DVMT Size

This item allows you to configure the maximum amount of memory DVMT will use when allocating additional memory for the internal graphics device.

Options: 256 MB (default), 128 MB, Max

### IGD--Boot Type

This item allows you to configure the boot display output method.

Options: VBIOS Default (Default), VGA, VGA2

## PCI Express Graphics

This option allows you to configure the external PCI Express Graphics card.

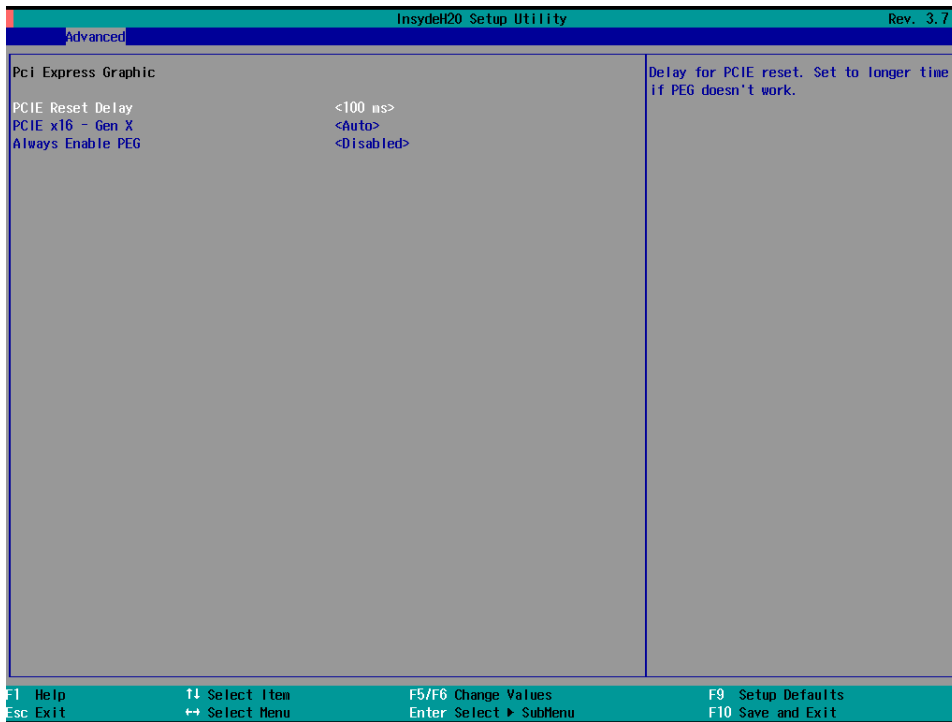

### PCIE Reset Delay

When the PCI-E x16 card cannot be detected, try to modify this setting.

Options: 100ms (Default), 50ms, 200ms, 300ms

### PCIEx16-GEN X

Set the PCIEx16 interface speed. The default is auto-detect. You can set a fixed speed for when a card cannot be detected.

Options: Auto (Default), Gen1, Gen2, Gen3

### Always Enable PEG

When the system doesn't detect a PCIEx16 card, it will disable the PCIe x16 interface to free up resources. Setting this item to enabled will ensure that the interface is always enabled.

Options: Disabled (Default), Enabled

## Chipset Configuration

This item allows you to configure the chipset settings.

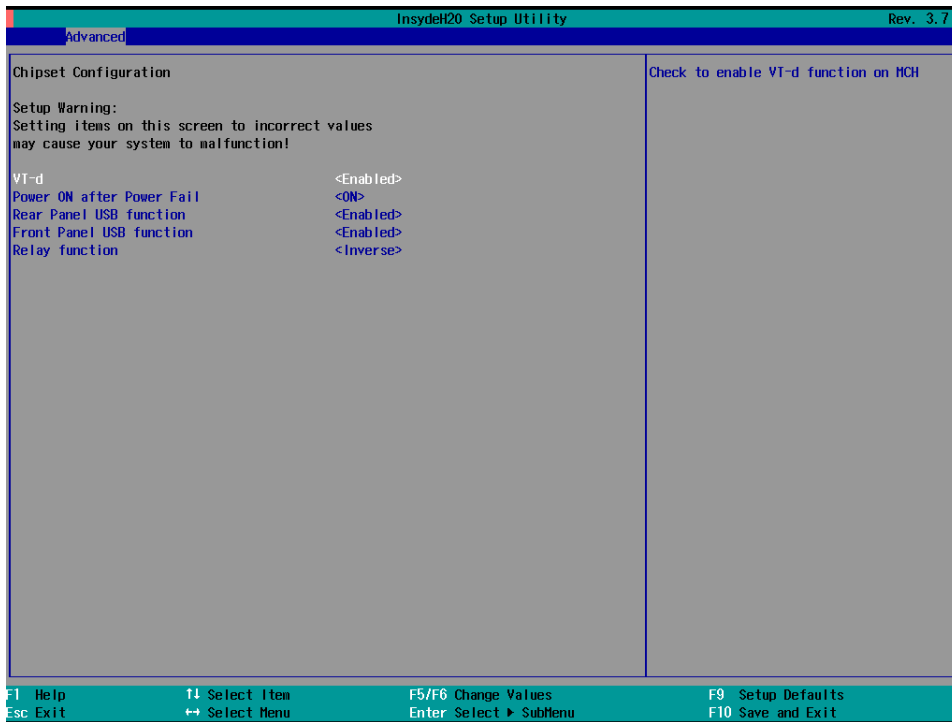

### Vt-d

This item allows you to enable/disable the Intel® Virtualization Technology For Directed I/O.

Options: Enabled (default), Disabled

### Power ON after Power Failure

This item allows you to enable/disable the computer from automatically powering up after a system crash.

Options: ON (default), OFF, Last State

### Rear Panel USB function

This item allows you to enable/disable the USB functions on the rear panel in order to restrict USB accessibility for security reasons.

Options: Enabled (default), Disabled

### Front Panel USB function

This item allows you to enable/disable the USB functions on the front panel in order to restrict USB accessibility for security reasons.

Options: Enabled (default), Disabled

## Relay function

This item allows you to configure relay alarm handling.

Options: Inverse (default), Normal

## Active Management Technology Support

This item allows you to configure the Intel® Active Management Technology.

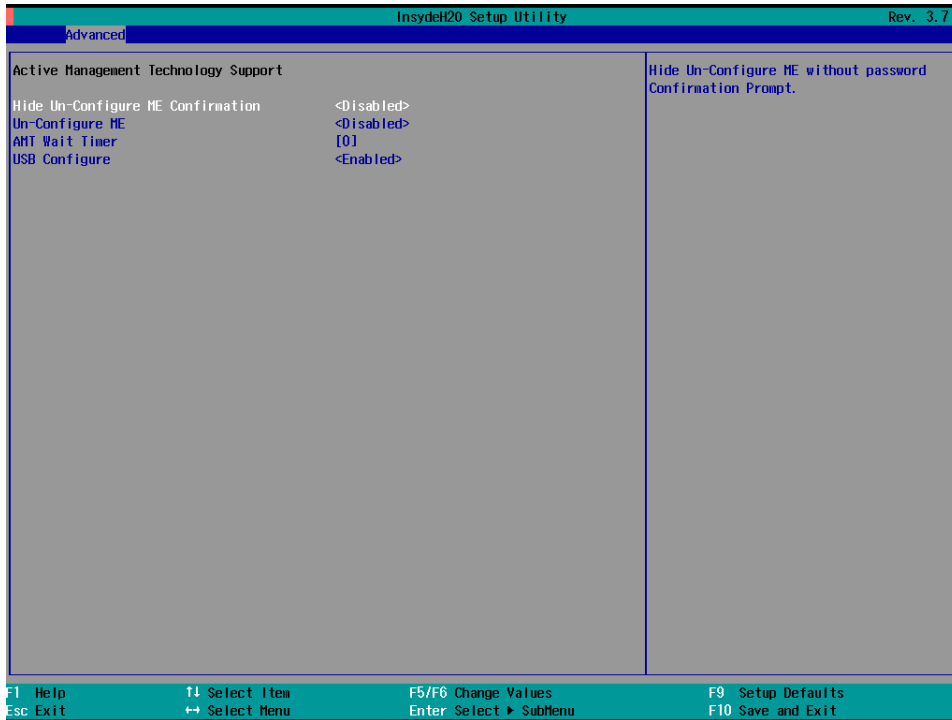

### Hide Un-Configure ME Confirmation

This item allows you to enable/disable hide un-configure ME without password confirmation prompt.

Options: Disabled (default), Enabled

### Un-Configure ME

This item allows you to enable/disable hide un-configure ME without password.

Options: Disabled (default), Enabled

### AMT Wait Timer

This item allows you to set how many seconds the timer waits before sending ASF\_GET\_BOOT\_OPTIONS.

### USB Configure

This item allows you to enable/disable the USB configure function.

Options: Enabled (default), Disabled

# PCI Express Configuration

This item allows you to configure PCIe slot settings.

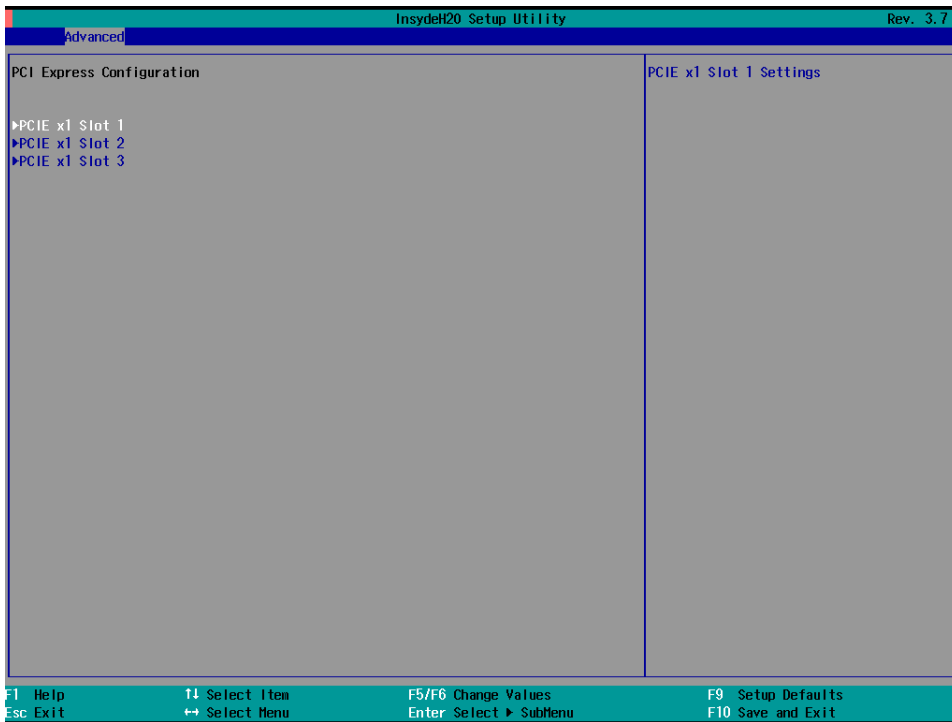

## PCIe x 1 Slot <1 to 3>

This item allows you to configure the PCIe speed of each PCIe x1 slot.

Options: Auto (default), Gen1, Gen2

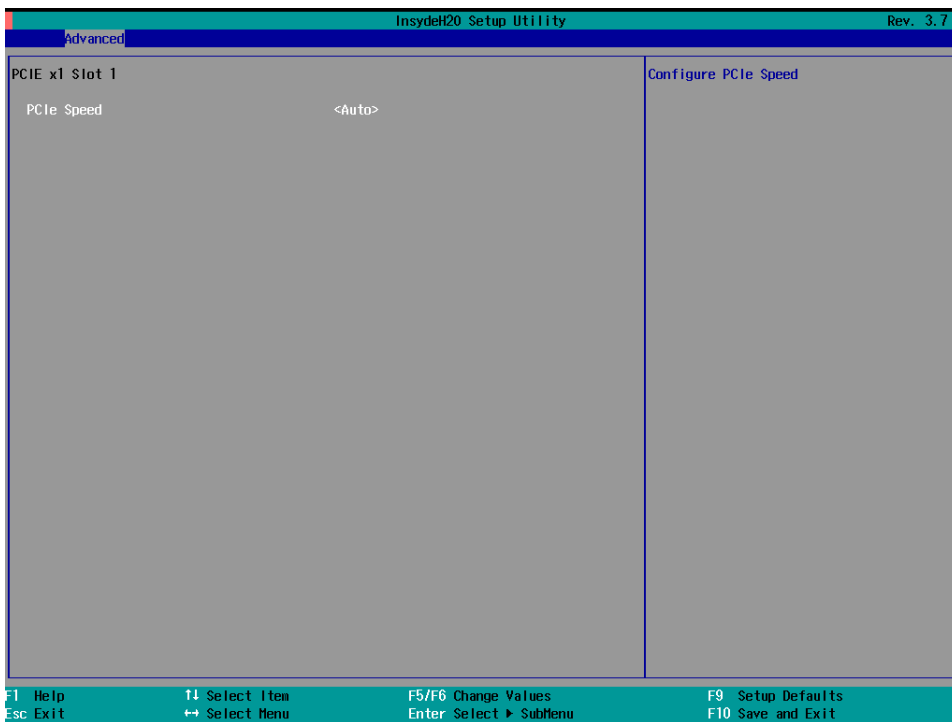

## Hardware Monitor

This item allows you to view stats such as CPU and system temperature, voltage levels, and other chipset information.

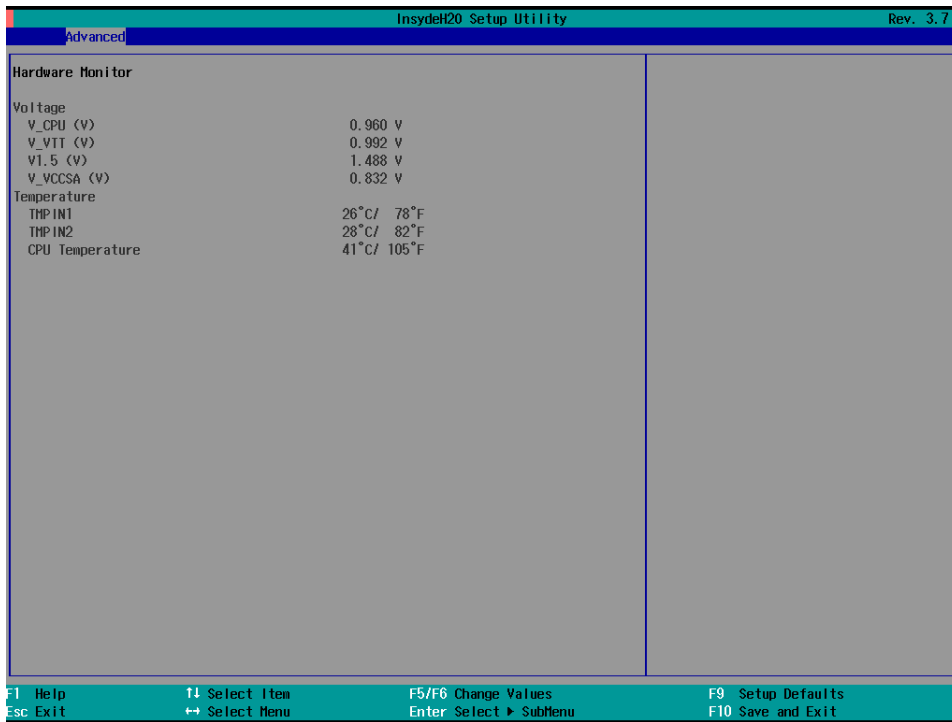

The voltage values will vary depending on which model you purchased. There is a 5% tolerance for temperature values. Note that at 100°C the accuracy of CPU temperature readings are in the range of -5°C to +10°C. This deteriorates to -10°C to +15°C at 50°C. The CPU temperature readings are saturated at some point below 50°C. Any CPU reading below 50°C is unreliable, and may only be interpreted as indicating a temperature below 50°C. For system temperature, there is a 5% tolerance for the temperature values.

## SMART RECOVERY Info

This item allows you to view the status of smart recovery settings.



### Load SMART RECOVERY Default

This item allows you to load the Smart Recovery default value. Refer to the Smart Recovery Website: <http://www.moxa.com/product/Smart-Recovery.htm> for details.

Options: Yes (default), No

**NOTE** Smart Recovery is not supported under RAID mode.

# Security Settings

This section allows users to configure security-related settings with a supervisor password and user password.

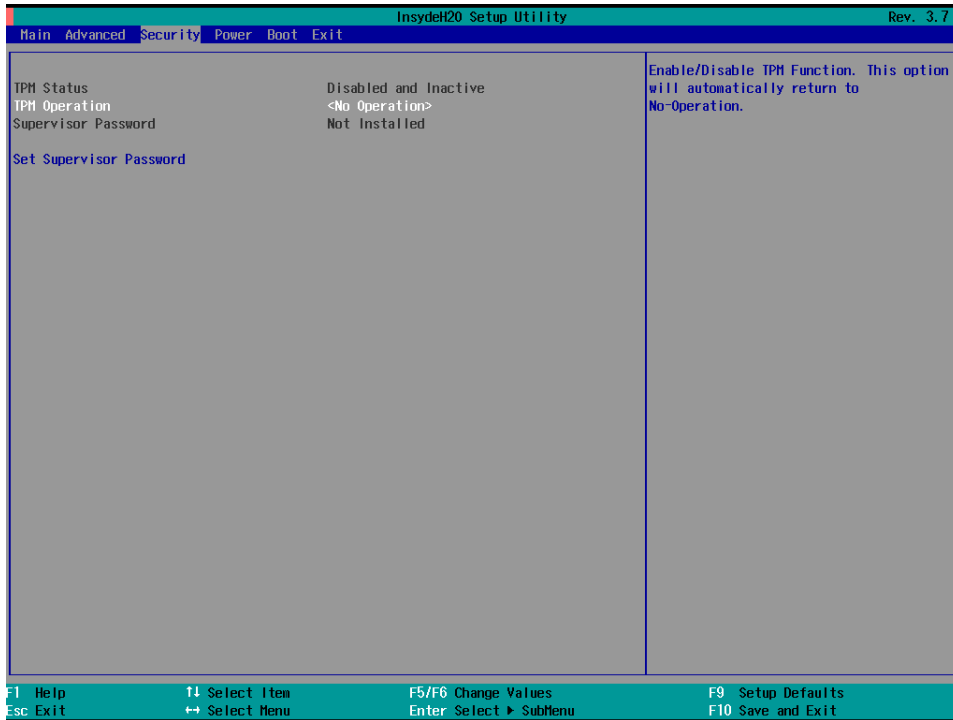

## TPM Status

This item allows you view the status of current TPM settings.

## TPM Operation

This item allows you enable/disable the TPM. When an operation is completed, this item will be reset to No Operation. The change will be executed after the next reboot.

Options: No Operation (default), Disable and Deactivate, Enabled and Active



## TPM Force Clear

This item allows the user to clear the TPM password. It is used when the user forgets the password. Note that all data protected by TPM will not be accessible.

Options: Disabled (default), Enabled



## Set Supervisor Password

This item allows you set the supervisor password. Select and then enter the password, and then confirm the password again.

To delete the password, enter **Set Supervisor Password** and then enter the old password; leave the new password fields blank, and then press enter.

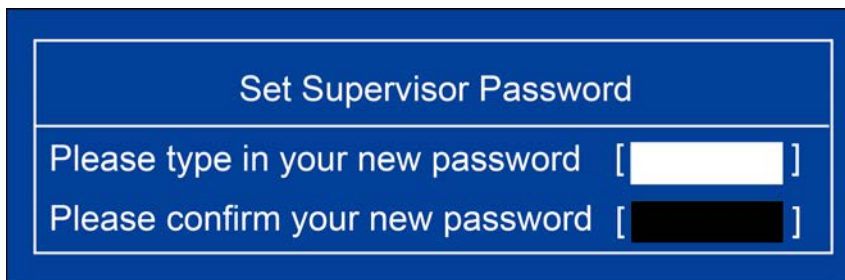

# Power Settings

The section allows users to configure power settings.

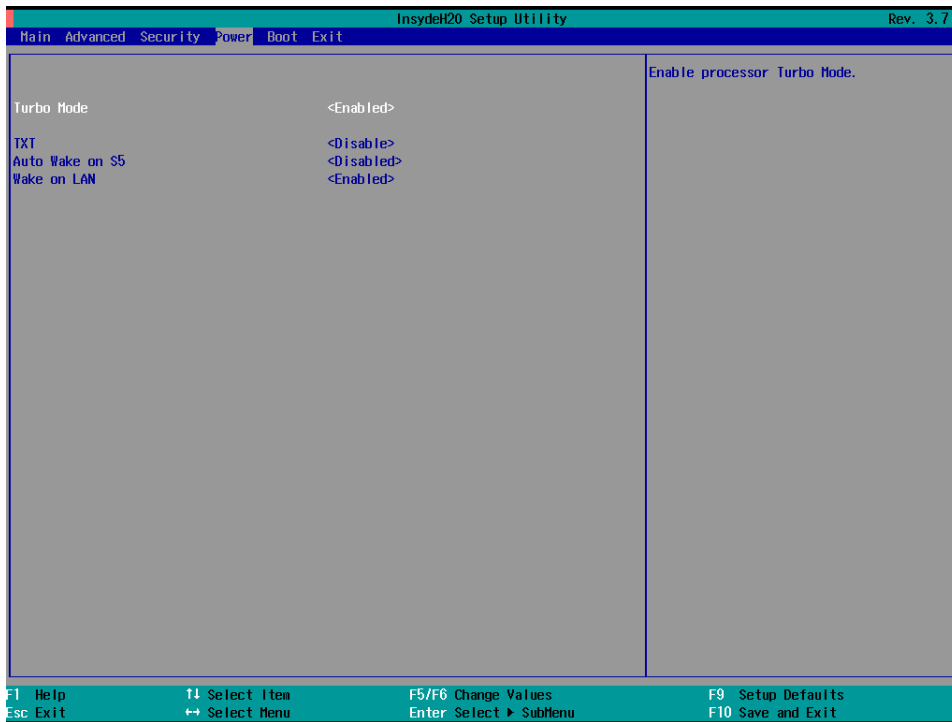

## Turbo Mode

This item allows users to determine whether to enable the Intel CPU Turbo Boost technology.

Options: Enabled (default), Disabled

## TXT

This item allows users to enable/disable Intel Trusted Execution Technology (Intel TXT).

Options: Disabled (default), Enabled

## Auto Wake on S5

This item allows you to configure the computer to wake from S5 status. S5 stands for Soft Off, where the PSU remains engaged but power to all other parts of the system is cut. Auto-wake on S5 schedules a soft-reboot at certain periodic times that may be specified in the BIOS.

Options: Disabled (default); By Every Day (user specifies a regular daily time when the computer will power up); By Day of Month (user specifies a regular day each month when the computer will power up)

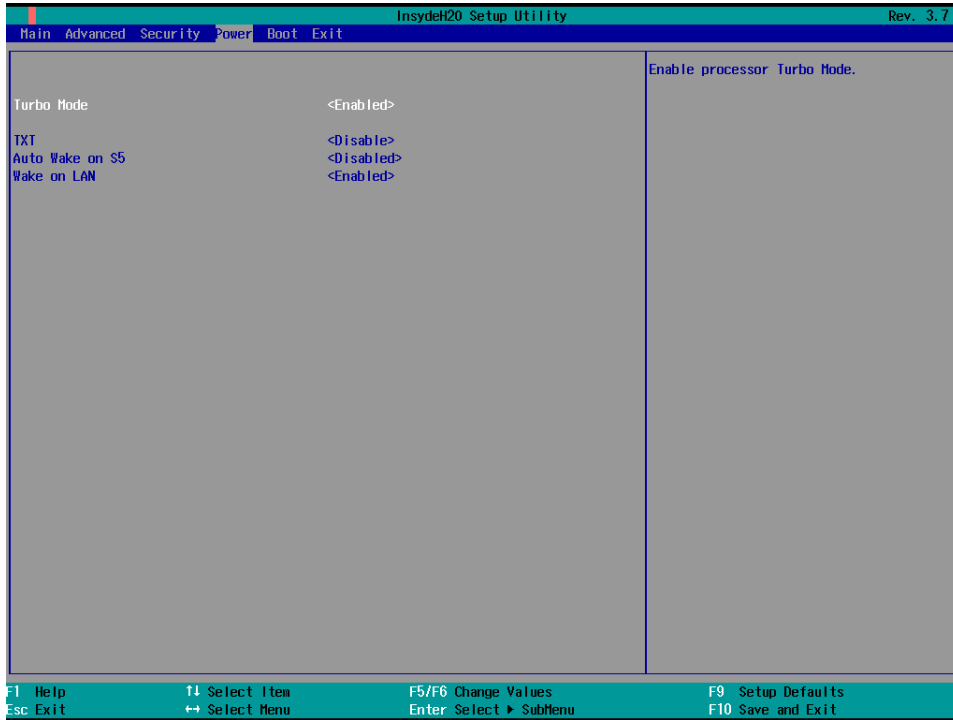

## Wake on LAN

This feature is used to wake the system by a LAN device from a remote host.

Options: Enabled (default), Disabled

# Boot Settings

The section allows users to configure boot settings.

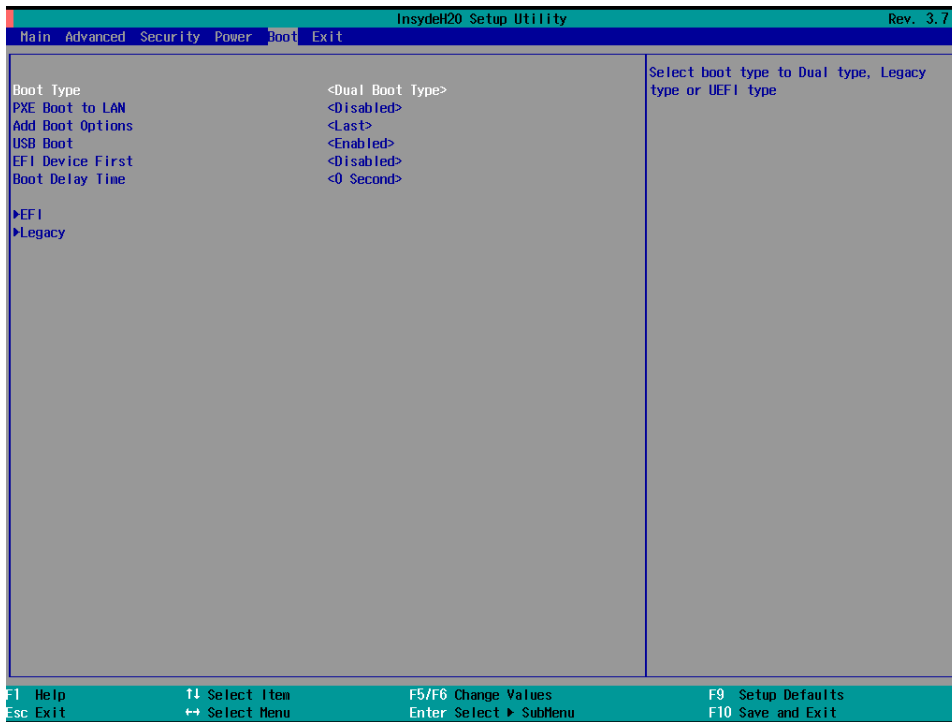

**NOTE** If you do not add any storage, you will not see the Legacy option.

## Boot Type

This item allows you to enable/disable the quick boot function.

Options: Dual Boot Type (default), Legacy Boot Type, UEFI Boot Type

## PXE Boot to LAN

This item allows you to enable/disable the PXE boot to LAN function.

Options: Disabled (default), Enabled

## Add Boot Options

This item allows you to add the boot order options for shell, network, and Removables.

Options: Last (default), First

## USB Boot

This item allows you to enable/disable the USB boot function.

Options: Enabled (default), Disabled

## EFI Device First

This item allows you to determine if the EFI device is activated first, or the legacy device is activated first. If enabled, EFI device will be the first; if disabled, legacy device will be the first.

Options: Disabled (default), Enabled

## Boot Delay Time

This item allows you to configure the delay time value for users to input the hot key during POST time.

Options: 0 Second (default), 3 Seconds, 5 Seconds, 10 Seconds

## Legacy

### Normal Boot Menu

This item allows you to configure the boot menu.

Options: Normal (default), Advanced

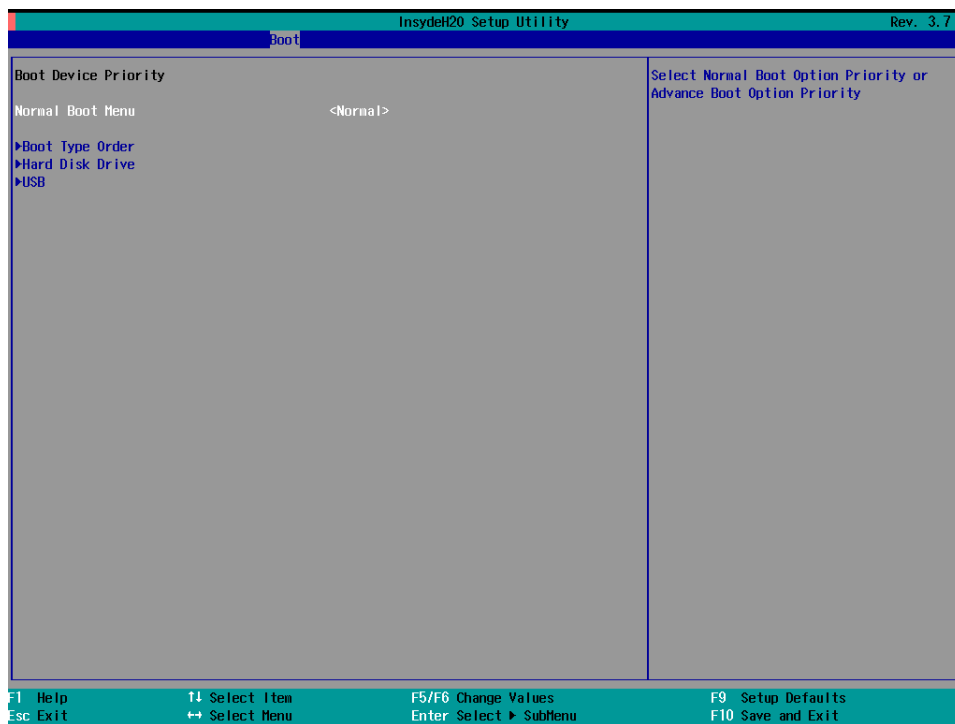

## Boot Type Order

This item allows you to select the boot order. Use +/F5 (move up) or -/F6 (move down) to change values.

Options: Hard Disk Drive (default), CD/DVD-ROM Drive, USB, Others

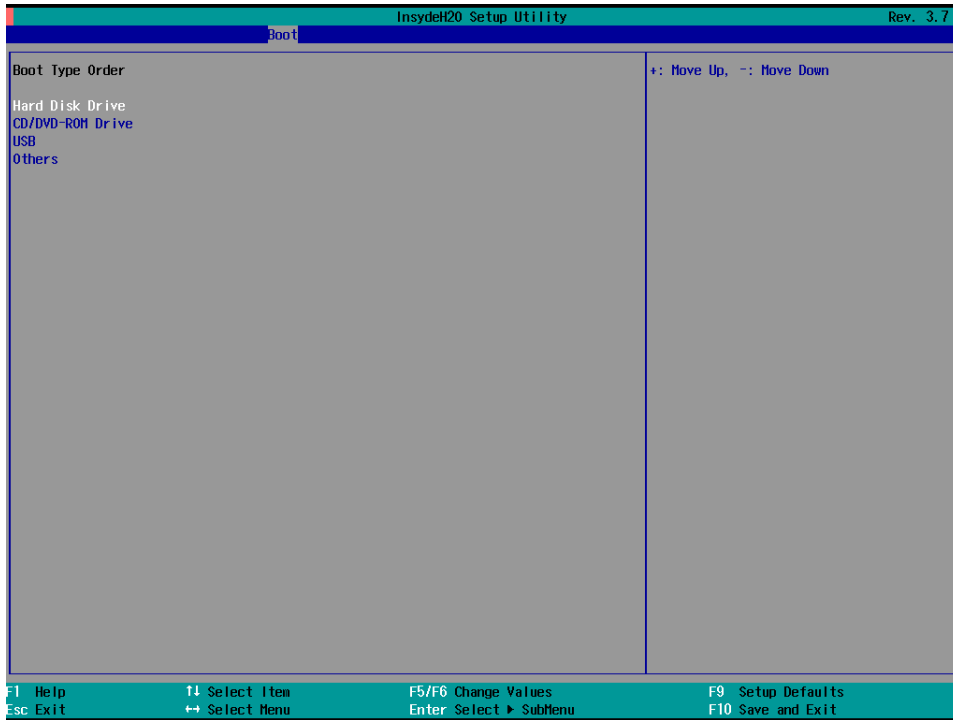

## Hard Disk Drive/USB Drive

This item allows you to view installed devices such as hard disk drives, USB drives, or CD-ROMs. For example, if you have inserted a USB drive into the computer, it will appear here.

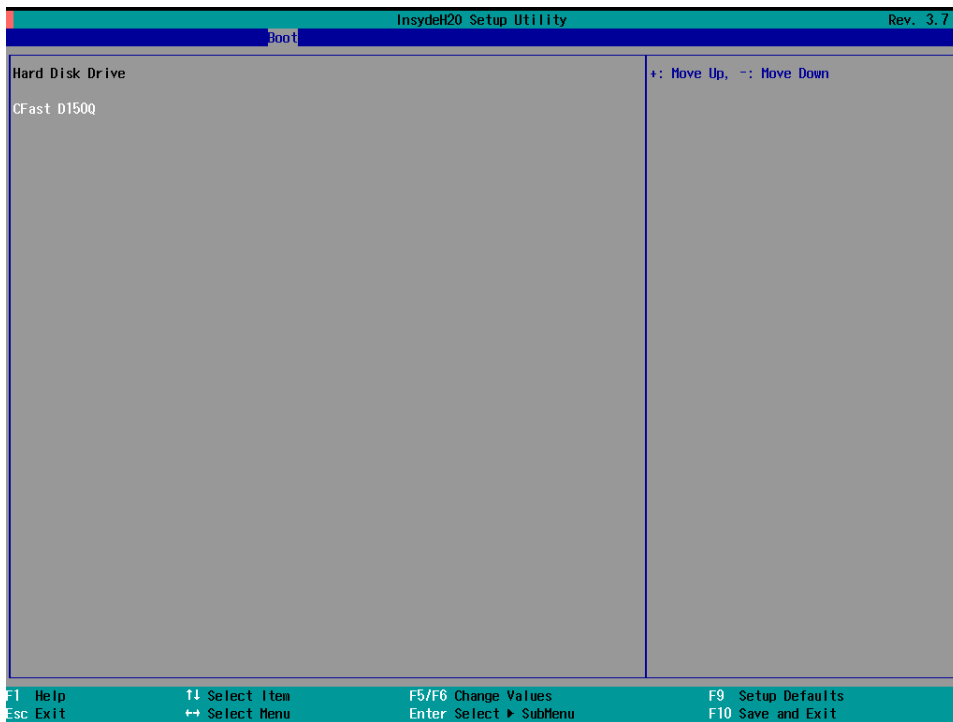

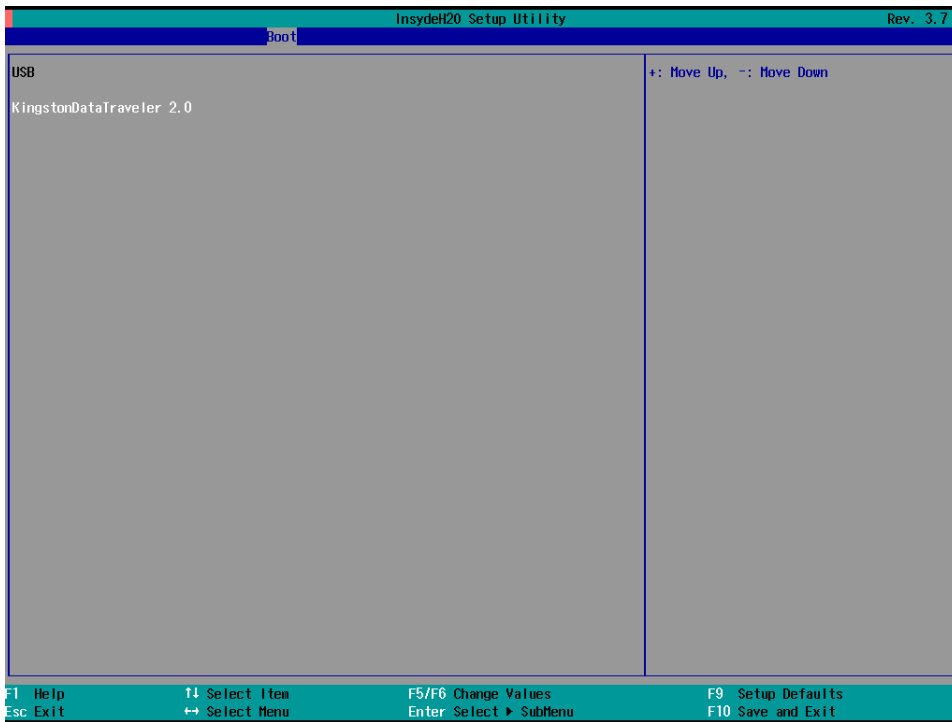

## Exit Settings

The section allows users to exit the BIOS environment.

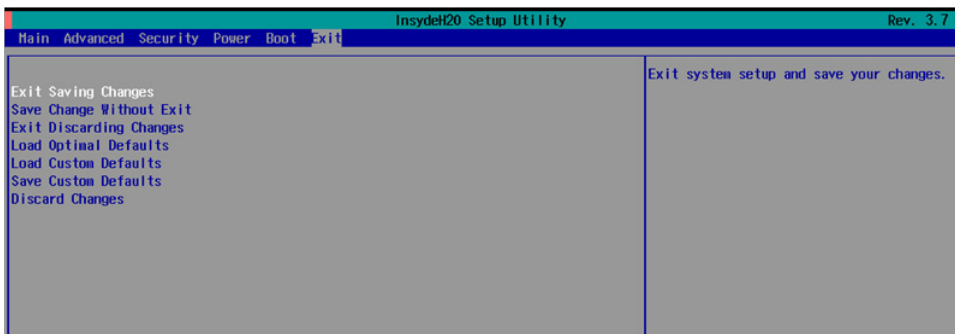

### Exit Saving Changes

This item allows you to exit the BIOS environment and save the values you have just configured.

Options: Yes (default), No

### Save Change Without Exit

This item allows you to save changes without exiting the BIOS environment.

Options: Yes (default), No

### Exit Discarding Changes

This item allows you to exit without saving any changes that might have been made to the BIOS.

Options: Yes (default), No

## Load Optimal Defaults

This item allows you to revert to the factory default BIOS values.

Options: Yes (default), No

## Load Custom Defaults

This item allows you to load custom default values for the BIOS settings.

Options: Yes (default), No

## Save Custom Defaults

This item allows you to save the current BIOS values as a “custom default” that may be reverted to at any time by the “load custom defaults” selection just above.

Options: Yes (default), No

## Discard Changes

This item allows you to discard all settings you have just configured.

Options: Yes (default), No

## Enable AMT

To enter the BIOS setup utility, press the “F2” key while the system is booting up. The main **BIOS Setup** screen will appear. Five options will be available:

- **Continue:** Continue to boot up
- **Boot Manager:** Select the device for booting up
- **Boot From File:** Select the UEFI boot up file
- **SCU:** Enter the BIOS configuration menu
- **MEBx:** Enter the AMT configuration menu



1. Select **MEBx** to enter the **AMT configuration**.

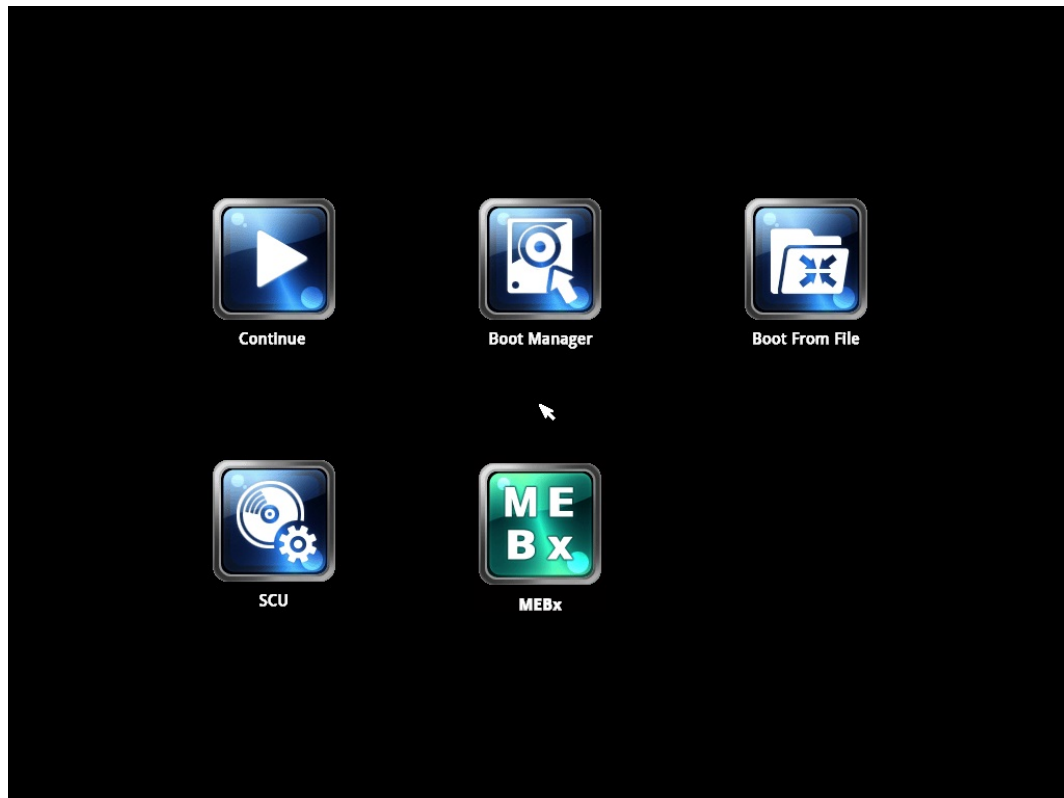

2. Press **<Enter>** to start the login procedure.

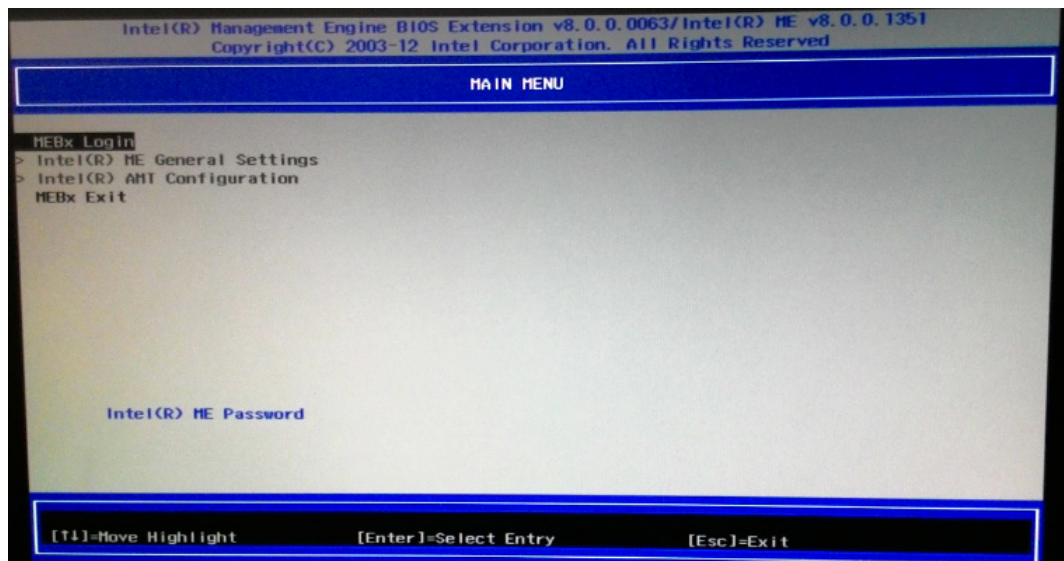

3. Type the default password: **admin**

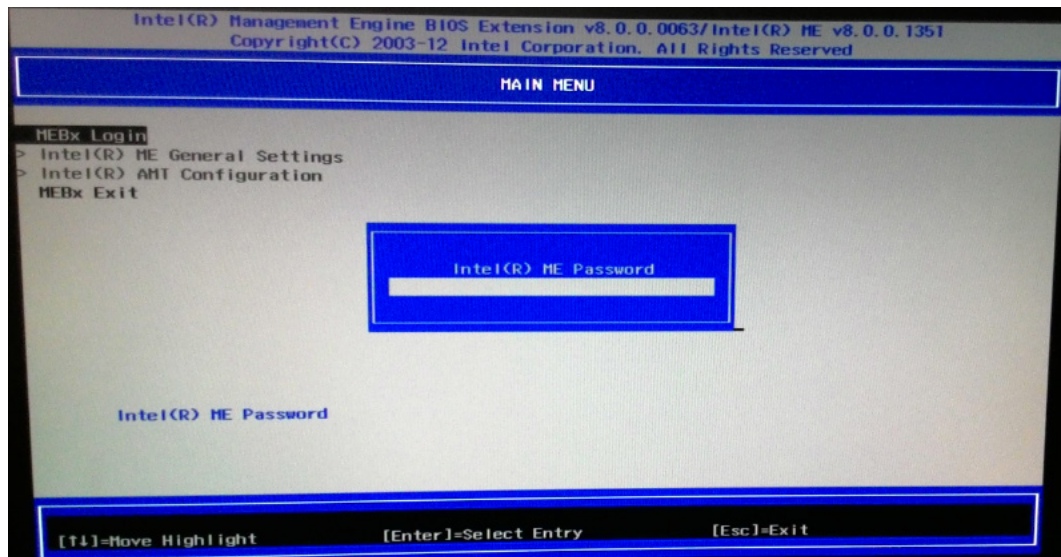

4. Type the new password. It must include both upper-case and lower-case characters, numbers, and special symbols. E.g., **Admin'12**.

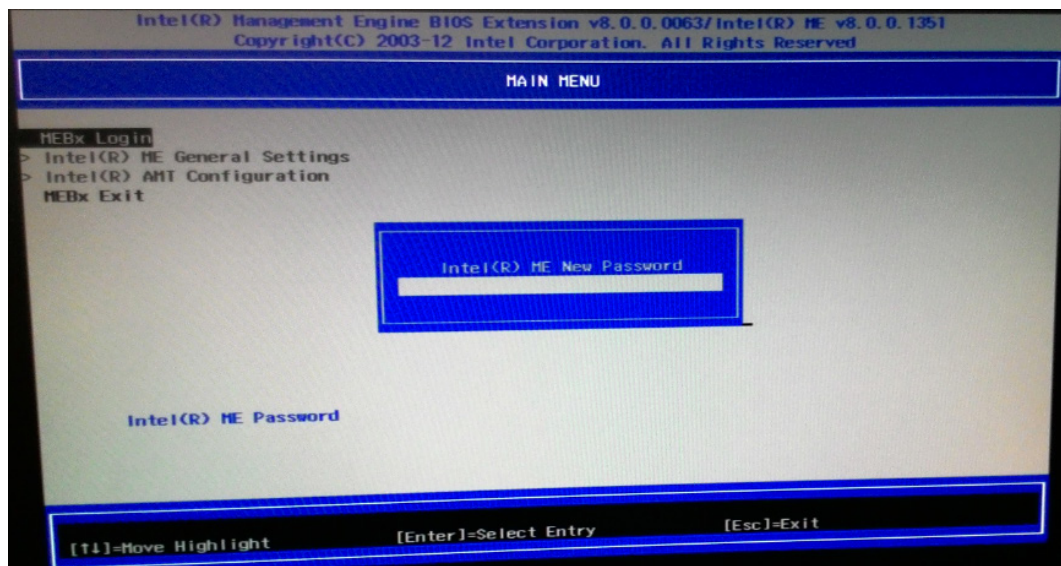

5. To enable remote access without a local user present for consent, select **User Consent**, and then select **User Opt-in** and change the value to **None**.

- 6. Set static IP or DHCP by request.

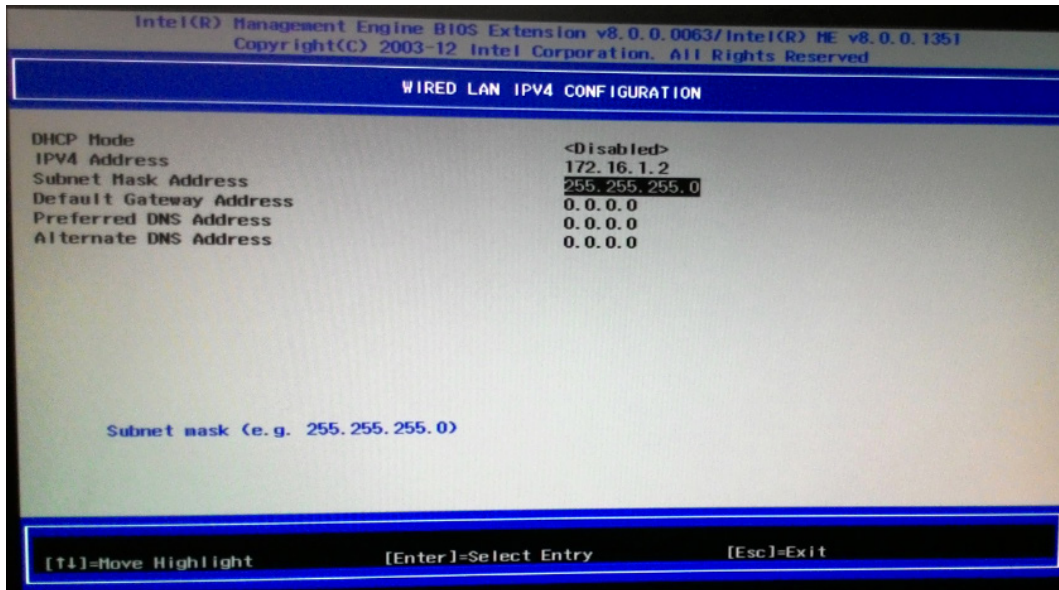

- 7. Set **Activate Network Access** to enable remote access capability.

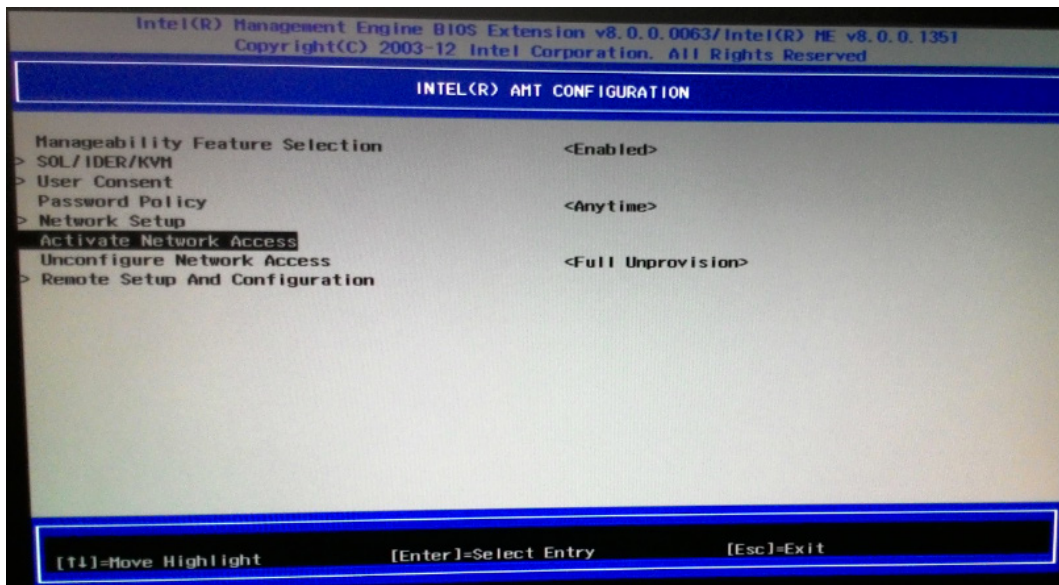

## Use AMT

You can use any of the available AMT tools to execute the remote management function. The easiest method is using a web browser.

1. Type the IP for your DA-820 that was configured in the AMT configuration with port **16992**. The AMT logon screen will appear.



2. Click on "Log On" and type the username (**admin**) and password to log in and control the DA-820 remotely.

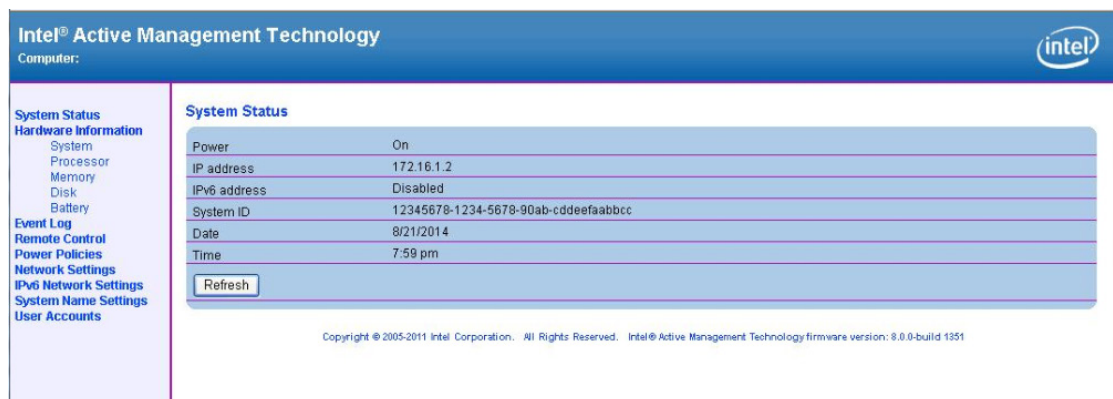

**NOTE** The DA-820's AMT port is LAN4.

**NOTE** Refer to the Intel AMT Implementation and Reference Guide for details:

[https://software.intel.com/sites/manageability/AMT\\_Implementation\\_and\\_Reference\\_Guide/default.htm?url=WordDocuments%2Faccessingintelamtviathewebuiinterface.htm](https://software.intel.com/sites/manageability/AMT_Implementation_and_Reference_Guide/default.htm?url=WordDocuments%2Faccessingintelamtviathewebuiinterface.htm)

## Upgrading the BIOS

This section describes how to upgrade the BIOS. However, note that it is easy to permanently damage the computer when upgrading the BIOS. We strongly recommend that you contact Moxa's technical support staff for assistance in order to obtain all the necessary tools and the most current advice before attempting to upgrade the BIOS on any Moxa device.

### Step 1: Create a Bootable USB Disk

Before upgrading the BIOS, every user should first create a bootable USB RAM drive as a system rescue device. A useful software suite for building USB RAM drives can be found by searching for Rufus, which may then be downloaded and used to create a bootable RAM drive. Take the following steps to create a bootable USB disk using Rufus.

1. Start Rufus from the Device drop-down list and select the USB device that you want to use as a bootable disk.
2. Select **MBR partition scheme for BIOS or UEFI computers**, to allow it to boot from legacy BIOS or UEFI.
3. Select **FAT (Default)** from the File system drop-down list.
4. Select **16 kilobytes (Default)** for Cluster size.
5. Enter a drive name in the New volume label.
6. Check **Quick format**, **Create a bootable disk using FreeDOS**, and **Create extended label and icon files**.
7. Click **Start** to format and create the bootable USB drive.

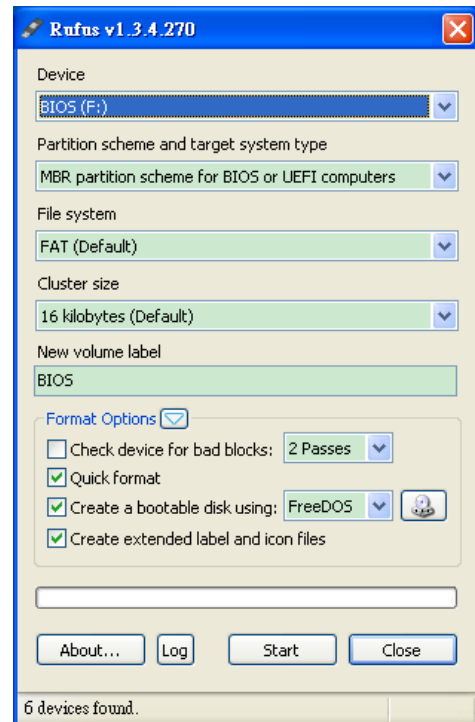

#### ATTENTION

We suggest using a USB drive with under 2 GB of disk space, since larger USB drives may not support the FAT file format and consequently fail to boot.

### Step 2: Prepare the Upgrade File

You must use the BIOS upgrade installation file to upgrade the BIOS. Contact Moxa's technical department for assistance.

1. Get the BIOS upgrade installation file. The file name should have the following format: **682AxxSx.exe** (xx refers to version numbers).
2. Copy the file to the Bootable USB Disk.

### Step 3: Run the upgrade program on the DA-820 Computer

1. Reboot the computer, and press F2 while booting up to go to the Boot Manager.
2. Select USB Disk as the first boot source, and then press Enter to continue.



3. When boot up finishes, a DOS screen will appear. Go to the directory where the upgrade file is located. For example, if the upgrade file is stored in the DA820 folder, type `cd DA820`

```
C:\>cd DA820
```

4. Run the upgrade program by typing `82010S6.exe`. Note that the upgrade filename may vary depending on the version.

```
C:\DA820>82010S6.exe
```

5. The upgrade program will run automatically. Wait patiently until the procedure is finished.

```
C:\>DA820\82010S6.exe
Reading file...
Flash package mode.
Option: -BIOS -C -Desc -ME
```

**Please do not remove the AC power!**

```
Insyde Flash Utility for InsydeH20
                          Version 1.5t
```

```
Initializing
```

```
Current BIOS Model name: DA820
New BIOS Model name: DA820
```

```
Current BIOS version: V1.00S06
New BIOS version: V1.00S06
```

```
Updating Block at FFFFF000
Flash Complete!
```

- When the upgrade is finished, the computer will automatically reboot. You may check the BIOS version on the Main page of the BIOS Setup

MODEL NAME	DA820
BIOS Version	V1.00S06

**ATTENTION**

Do NOT switch off the power supply during the BIOS upgrade, since doing so may cause the system to crash.

## Safety Installation Instructions

---

### A. RTC Battery Warning

**CAUTION:** There is a risk of explosion if the battery is replaced by an incorrect type. Dispose of used batteries according to the instructions.

### B. Fuse Warning

**CAUTION:** For continued protection against fire, replace only with the same type and rating of fuse.

### C. Rackmount Warning

The following or similar rackmount instructions are included with the installation instructions:

**(1) Elevated Operating Ambient:** If installed in a closed or multi-unit rack assembly, the operating ambient temperature of the rack environment may be greater than the room ambient temperature. Therefore, consideration should be given to installing the equipment in an environment compatible with the maximum ambient temperature (T<sub>ma</sub>) specified by the manufacturer.

**(2) Reduced Air Flow:** Installation of the equipment in a rack should be such that the amount of air flow required for safe operation of the equipment is not compromised.

**(3) Mechanical Loading:** Mounting of the equipment in the rack should be such that a hazardous condition is not achieved due to uneven mechanical loading.

**(4) Circuit Overloading:** Consideration should be given to the connection of the equipment to the supply circuit and the effect that overloading of the circuits might have on overcurrent protection and supply wiring. Appropriate consideration of equipment nameplate ratings should be used when addressing this concern.

**(5) Reliable Grounding:** Reliable grounding of rack-mounted equipment should be maintained. Particular attention should be given to supply connections other than direct connections to the branch circuit (e.g., by using power strips).